

Certification Test Plan

Document Number: ESS-7001-CTP-01

Prepared for:

Vendor Name	<i>Election Systems and Software (ES&S)</i>
Vendor System	<i>EVS 6.0.0.0</i>
EAC Application No.	<i>EVS6000</i>
Vendor Address	<i>11208 John Galt Boulevard Omaha, Nebraska 68137</i>

Prepared by:



4720 Independence St.
Wheat Ridge, CO 80033
303-422-1566
www.SLICompliance.com



Accredited by the Election Assistance Commission (EAC) for Selected Voting System Test Methods or Services

Copyright © 2017 by SLI ComplianceSM, a Division of Gaming Laboratories International, LLC

Revision History

Date	Version	Author	Revision Summary
October 10 th , 2017	1.0	M. Santos	Initial Draft
December 12 th , 2017	1.1	M. Santos	Updates for EAC comments

Disclaimer

The information reported herein must not be used by the client to claim product certification, approval, or endorsement by NVLAP, NIST, or any agency of the Federal Government.

Trademarks

- SLI is a registered trademark of SLI Compliance.
- All products and company names are used for identification purposes only and may be trademarks of their respective owners.

TABLE OF CONTENTS

CERTIFICATION TEST PLAN	1
1 INTRODUCTION	5
1.1 CERTIFICATION TEST PLAN ATTACHMENTS	5
1.2 REFERENCES	5
1.3 TERMS AND ABBREVIATIONS	6
1.4 PROJECT OVERVIEW	8
1.5 PURPOSE.....	8
1.6 TESTING RESPONSIBILITIES.....	8
1.6.1 <i>Project Schedule</i>	8
1.7 SCOPE OF TESTING	10
1.8 SCOPE OF THE ES&S EVS 6.0.0.0 VOTING SYSTEM	12
1.8.1 Configurations	12
1.8.2 <i>System Overview</i>	14
1.8.3 Block Diagrams	19
1.8.4 <i>System Limits</i>	22
1.8.5 <i>Supported Languages</i>	24
1.8.6 <i>Supported Functionality</i>	25
1.8.7 <i>Excluded Requirements</i>	25
1.8.8 <i>Additional Functionality/Requirements</i>	26
1.9 CHANGE CONTROL AND CONFIGURATION MANAGEMENT	29
2 PRE-CERTIFICATION TESTING AND ISSUES.....	31
2.1 EVALUATION OF PRIOR VSTL TESTING.....	31
2.2 EVALUATION OF PRIOR NON-VSTL TESTING	31
2.3 KNOWN VULNERABILITIES	31
3 PHYSICAL CONFIGURATION AUDIT	31
3.1 TDP DOCUMENTATION ANALYSIS & REVIEW	31
3.1.1 <i>Document Review</i>	31
3.2 TDP SOURCE CODE ANALYSIS & REVIEW	32
3.2.1 <i>Source Code Review</i>	32
3.3 QA & CM PROCESS REVIEW	33
3.4 COMPLIANCE/TRUSTED BUILD.....	33
4 MATERIALS REQUIRED FOR TESTING.....	34
4.1 SOFTWARE/FIRMWARE	34
4.1.1 <i>Manufacturer Software/Firmware</i>	34
4.1.2 <i>COTS Software/Firmware</i>	35
4.1.3 <i>Additional Supporting Test Software</i>	36
4.2 EQUIPMENT.....	36
4.2.1 <i>ES&S EVS 6.0.0.0 Equipment</i>	36
4.2.2 <i>COTS Equipment</i>	37
4.3 TEST MATERIALS.....	39
4.4 DELIVERABLE MATERIALS	40
5 TEST SPECIFICATIONS.....	43
5.1 REQUIREMENTS.....	43
5.2 HARDWARE CONFIGURATION AND DESIGN	44
5.3 TESTING STRATEGIES.....	44
5.3.1 <i>How each Polling Place Device will be tested</i>	44
5.3.2 <i>How each Application will be tested</i>	46
5.4 SOFTWARE SYSTEM FUNCTIONS	46
5.4.1 <i>Election Definition Creation</i>	46

5.4.2	Pre-voting Aspects	46
5.4.3	Voting Aspects – Polling Place.....	47
5.4.4	Voting Aspects – Central Count	47
5.4.5	Post-voting Aspects.....	47
5.4.6	Error Messaging and Recovery.....	47
5.4.7	Auditing.....	47
5.4.8	Security.....	47
5.5	TEST SUITE DESIGN	47
5.5.1	Hardware Qualitative Examination Design.....	47
5.5.2	Hardware Environmental Test Design.....	48
5.5.3	Software Module Test Design and Data.....	48
5.5.4	Software Functional Test Design and Data.....	48
5.5.5	System-level Test Design.....	49
5.5.6	Software Functional Test Case Design	50
5.5.7	System-level Test Suite Design	52
5.6	STANDARD VSTL TEST METHODS AND UNCERTAINTY OF TEST DATA MEASUREMENT	58
5.7	EAC INTERPRETATIONS.....	58
5.8	SECURITY FUNCTIONS	60
5.8.1	Security Test.....	60
6	TEST DATA.....	60
6.1	DATA RECORDING	61
6.2	TEST DATA CRITERIA.....	61
6.3	TEST DATA REDUCTION.....	61
7	TEST PROCEDURE AND CONDITIONS	62
7.1	FACILITY REQUIREMENTS.....	62
7.2	TEST SETUP.....	62
7.3	TEST SEQUENCE	62
8	TEST OPERATIONS PROCEDURES	63
9	APPROVAL SIGNATURES	63
10	APPENDIX A – ANCILLARY PRODUCTS.....	64

1 INTRODUCTION

This Certification Test Plan outlines the test approach SLI Compliance (SLI) will follow when performing Certification Testing on the **ES&S EVS 6.0.0.0** voting system against the 2005 Voluntary Voting System Guidelines (VVSG). The purpose of this document is to provide a clear understanding of the work SLI will conduct and a detailed plan outlining the test effort.

When the testing is complete, SLI will submit a Certification Test Report that details all test results and findings from the Certification Test effort, as well as a recommendation to the EAC.

1.1 Certification Test Plan Attachments

The following attachments apply to this Certification Test Plan:

1. Attachment A - Elec_NTS_Longmont_A2LA_0214-43_022818
2. Attachment B - ENV_NTS_Longmont_A2LA_0214-44_022818
3. Attachment C - ESS EV6000 Electrical Hardware Test Plan v2.3
4. Attachment D - ESS EV6000 Environmental Hardware Test Plan v2.2

1.2 References

The following key documents were used in preparing this test plan.

1. Election Assistance Commission Voluntary Voting System Guidelines (EAC VVSG), 2005 Version 1.0 Volumes I and II.
2. NIST Handbook 150: 2016.
3. NIST Handbook 150-22: 2017.
4. EAC Voting System Testing and Certification Program Manual, United States Election Assistance Commission, v 2.0, May 2015
5. SLI VSTL Quality System Manual, 2.3, prepared by SLI, dated January 20, 2017.

1.3 Terms and Abbreviations

The following terms and abbreviations will be used throughout this document:

Table 1 – Terms and Abbreviations

Term	Abbreviation	Description
American Association for Laboratory Accreditation	A2LA	A nonprofit, non-governmental, public service, membership society whose mission is to provide comprehensive services in laboratory accreditation and laboratory-related training.
Ballot Marking Device	BMD	An accessible computer-based voting system that produces a marked ballot (usually paper) that is the result of voter interaction with visual or audio prompts.
Cast Vote Record	CVR	Permanent record of all votes produced by a single voter whether in electronic, paper or other form. Also referred to as ballot image when used to refer to electronic ballots.
Central Count Scanner	CCS	High Speed Optical Scanner is a mark sense-based ballot and vote counting device typically located at a central count facility and is operated by an automated multi-sheet feeding capability.
Compact Flash card	CF	This is a type of flash memory card in a standardized enclosure often used in voting systems to store ballot and/or vote results data.
Commercial Off the Shelf	COTS	Term used to designate computer software, hardware or accessories that are ready-made and available for sale, lease, or license to the general public
Direct Recording Electronic	DRE	Voting systems that, using Touch Screen or other user interfaces, directly record the voter's selections in each race or contest on the ballot in electronic form.
Election Assistance Commission	EAC	An independent, bipartisan commission created by the Help America Vote Act (HAVA) of 2002 that operates the federal government's voting system certification program.
Election Management System	EMS	Typically a database management system used to enter jurisdiction information (district, precincts, languages, etc.) as well as election specific information (races, candidates, voter groups (parties), etc.). In addition, the EMS is also used to layout the ballots, download the election data to the voting devices, upload the results and produce the final results reports.

Term	Abbreviation	Description
Electromagnetic Compatibility	EMC	The goal of EMC is to validate the correct functioning of different equipment in the same environment and the avoidance of any interference effects between them.
Functional Configuration Audit	FCA	The testing activities associated with the functional testing of the system.
National Institute of Standards and Technology	NIST	A non-regulatory federal agency within the U.S. Dept. of Commerce. Its mission is to promote U.S. innovation and industrial competitiveness by advancing measurement science, standards, and technology in ways that enhance economic security and improve our quality of life.
National Voluntary Laboratory Accreditation Program	NVLAP	A division of NIST that provides third-party accreditation to testing and calibration laboratories.
Physical Configuration Audit	PCA	Confirms that the documentation submitted meets the national certification requirements. Includes Trusted Build activities.
Precinct Count Scanner	PCS	A precinct-count optical scanner is a mark sense-based ballot and vote counting device located at a precinct and is typically operated by scanning one ballot at a time.
Request For Information	RFI	A means used by testing laboratories and manufacturers to request that the EAC provide an interpretation of a technical issue related to testing of voting systems.
Technical Data Package	TDP	The data package supplied by the vendor, which includes Functional Requirements, Specifications, End-user documentation, Procedures, System Overview, Configuration Management Plan, Quality Assurance Program, and manuals for each of the required hardware, software, firmware components of a voting system.
Universal Voting System	UVS	A device designed for all voters
Voluntary Voting System Guidelines	VVSG	A set of specifications and requirements against which voting systems can be tested to determine if the systems provide all of the basic functionality, accessibility and security capabilities required for EAC certification.
Voting System Test Lab	VSTL	An independent testing organization accredited by NVLAP and the EAC to conduct voting system testing for EAC certification.
Voting Test Specialist	VTS	An SLI employee within the Compliance division who has been qualified to perform EAC voting system certification testing.

1.4 Project Overview

This Test Plan outlines the approach SLI will implement to perform testing of the **ES&S EVS 6.0.0.0** voting system against the requirements of the federal 2005 Voluntary Voting System Guidelines (VVSG), Volumes 1 and 2. This project is for a new system certification effort.

1.5 Purpose

The purpose of this EAC Test Plan is to create clear and precise documentation of the processes that SLI, as an EAC VSTL, will implement throughout the course of voting system verification testing.

This Test Plan:

- Defines the overall test approach.
- Identifies required voting system hardware and software to be tested, and in what configurations.
- Identifies required hardware, software, and tools to be used to support the testing efforts.
- Defines the types of tests to be performed and against what declared functionality.
- Defines the types of election and vote data required for effective testing.
- Defines the types of voting system threats and vulnerabilities against which the voting system will be tested.
- Serves as a foundation for the development of **ES&S EVS 6.0.0.0** test suites
- Defines the process for recording and reporting test results.

1.6 Testing Responsibilities

The following schedule describes the high-level tasks and assigned personnel titles that will be involved in the Certification Test effort of the **ES&S EVS 6.0.0.0** voting system.

1.6.1 Project Schedule

The project schedule consists of the components listed in the following subsections:

1.6.1.1 Owner Assignments

- System Analysis and Review will be conducted by the Source Code Review (SCR) team, Security and Voting Test Specialists (VTS), with oversight by the Test Manager (TM)
- Source code review will be conducted by SCR Specialists, with oversight by the TM
- Documentation review will be conducted by Security and VTS personnel, with oversight by the TM
- Test Module Development and Validation will be conducted by Security and VTS personnel, with oversight provided by the TM

- Test Suite Development and Validation will be conducted by Security and VTS personnel, utilizing SLI’s formal Test Methods, with oversight provided by the TM
- Formal Test Execution will be conducted by Security and VTS personnel, with oversight by the TM
- 3rd Party testing will be conducted by the subcontracting 3rd Party Hardware Laboratories, with oversight by the Hardware Specialist

1.6.1.2 Test Module Development and Validation

Test Modules will be developed to provide repeatable detailed test steps. The Modules are designed for use in any suite that employs their functionality. The modules will be validated prior to Formal Test Execution to ensure accurate testing of the voting system. Test modules are validated by internal review and execution. The test modules and the test suites that are written by SLI contribute directly to the “Exhaustive verification of every system function and combination of functions cited in the vendor’s documentation”, as defined by the VVSG’s definition of the Functional Configuration Audit (FCA).

1.6.1.3 Test Suite Development

Test Suites will be developed to group and focus testing around key areas of the voting system. Each Test Suite will contain multiple test modules providing clear and traceable test scripts and information. Various system configurations will be identified within the suites. Under the 2005 VVSG, this portion of the certification is considered to be part of the FCA.

1.6.1.4 Formal Test Execution

Formal Test Execution of the validated Test Suites will be conducted against the declared voting system. A Compliance Build will be performed, producing software and firmware components, in order to test to determine whether or not the system is compliant with the VVSG requirements. Once all requirements are satisfactorily met, a Trusted Build will be performed to produce the final software and firmware deliverables. Additional testing will be performed to verify the final deliverables. Under the 2005 VVSG, this portion of the certification is considered to be part of the FCA.

1.6.1.5 3rd Party Hardware Testing

Hardware testing will be conducted by 3rd Party certified hardware test laboratories to verify the voting system devices are in compliance with the VVSG hardware requirements.

Other Labs Performing Non-Core Hardware Testing

SLI Compliance is responsible for all core voting system tests as identified in the NIST NVLAP Handbook 150-22 (2017). The labs listed below will perform non-core hardware testing for this certification test campaign.

Table 2 – Labs Performing Hardware Testing

Laboratory	Address	Test(s)	Date(s)
NTS – EMI / EMC	1736 Vista View Drive Longmont, CO 80504	EMC / EMI Tests: Radiated Emissions, Conducted Emissions, ESD, Electromagnetic	7/7/2017 – 9/12/2017

Laboratory	Address	Test(s)	Date(s)
		Susceptibility, Electrical Fast Transient, Lightning Surge, Conducted RF Immunity, Magnetic Fields Immunity, Electrical Power Disturbance	
NTS – Environmental / Dynamic	1601 Dry Creek Drive Suite 200 Longmont, CO 80503	MIL-STD-810D Tests: Bench Handling, Vibration, Low Temperature, High Temperature, Humidity, Temperature/Power Variation, and Reliability	7/7/2017 – 1/19/2018

1.6.1.6 EAC & Manufacturer Dependencies

The Test Plan will require EAC approval prior to finalization.

ES&S is required to provide all source code, documentation, equipment and supporting materials identified as part of the voting system.

All identified source code discrepancies must be resolved, be able to be built successfully, be installed, as well as successfully complete operational status checks prior to Formal Test Execution.

In addition, **ES&S** is required to provide training on the voting system and support throughout the life of the project.

1.7 Scope of Testing

SLI will provide testing on the **ES&S EVS 6.0.0.0** voting system based on the guidelines established for voting system verification testing as defined by the EAC's 2005 VVSG. This effort will include all required levels of software, firmware, system and hardware testing required to demonstrate that the **ES&S EVS 6.0.0.0** voting system is tested against the requirements of the 2005 VVSG.

SLI's major task categories for voting system verification testing, as defined by SLI's NVLAP audited and approved Quality System Manual, as well as the 2005 VVSG, include:

- Physical Configuration Audit (PCA)
 - Iterative documentation review and assessment
 - Iterative source code review
 - Trusted Builds/Compliance Builds. Identify the Trusted Build process to establish the system version and components being tested and ensure that the qualified executable release is built from the reviewed components.
 - Software and Hardware Configuration Audit. Verification of software and hardware physical and functional configurations.

Note that Documentation and Source Code Review are denoted as “Iterative”. When either Documentation or Source Code is reviewed, and items that do not meet the VVSG requirements are found, discrepancy reports are generated and sent to the manufacturer. Next, the manufacturer is allowed to resolve the issue and re-submit the item in question. SLI then re-reviews to verify that the requirement is met. (SLI also validates that nothing else has been modified; if something else was modified, it is also re-reviewed.)

- Functional Configuration Audit (FCA)
 - Review of other relevant state verification testing or risk analysis results.
 - Review of prior hardware testing results.
 - Testing of voting system components and the fully integrated system to validate functionality, logic processing, system performance, security, and system level integration. This testing includes the formal test execution, utilizing customized iterations of SLI’s formal Test Methods for the **ES&S EVS 6.0.0.0** voting system. Regression testing will be done when issues are found in testing and source code is modified, re-reviewed and re-built.
 - Accuracy testing and validation of a voting system's scanners ability to accurately read ballots and tally a large number of ballot marking positions within the requirements allowed by the 2005 VVSG.
 - Security testing and validation that a voting system is tested against all security related requirements as well as assessing the effectiveness of a voting system’s security controls.
 - Verification of every system function cited in the vendor’s documentation.
- Generation of detailed and repeatable test modules based on SLI’s formal Test Methods, to ensure the voting system is tested against all applicable requirements of the 2005 VVSG and associated **ES&S EVS 6.0.0.0** specific requirements.
- Generation of test data required for all test modules.
- Traceability of test modules to the requirements of the 2005 VVSG.
- Reporting of all test results.

SLI will develop and submit to the EAC a final test report for the **ES&S EVS 6.0.0.0** voting system.

1.8 Scope of the ES&S EVS 6.0.0.0 Voting System

1.8.1 Configurations

The **ES&S EVS 6.0.0.0** voting system is composed of the components detailed in section “1.8.2 System Overview”, below.

Within the scope of the **ES&S EVS 6.0.0.0** voting system, three unique configurations are supported, in order to accommodate limitations of components with the **EVS 6.0.0.0** voting system.

1.8.1.1 Test Configuration A

EVS6000: Test Configuration A encompasses all functionality of the voting system with the exceptions noted below. This configuration is comprised of the entire suite of voting system products listed in Section 1.2 and listed below.

Test configuration:

- Electionware
- ExpressVote Marker (HW v1.0)
- ExpressVote Marker/Tabulator (HW v2.1)
- ExpressVote XL
- ExpressTouch
- DS200
- DS450
- DS850

Excluded hardware:

- None

Excluded functionality:

- Open Primary
- Reviewer or Judges Initials boxes
- Multi-card ballot support
- Massachusetts Group Vote
- Universal Primary Contest
- Multiple Target Cross Endorsement
- Punjabi and Gujarati foreign language support

1.8.1.2 Test Configuration B

EVS6000: Test Configuration B encompasses all functionality of the voting system with the exceptions noted below. This configuration is comprised of the entire suite of voting system products listed in Section 1.2 with the exceptions noted below.

Test configuration:

- Electionware
- ExpressVote Marker (HW v1.0)

- ExpressVote Marker/Tabulator (HW v2.1)
- DS200
- DS450
- DS850

Excluded hardware:

- ExpressTouch
- ExpressVote XL

Excluded functionality:

- Punjabi and Gujarati foreign language support

1.8.1.3 Test Configuration C

EVS6000: Test Configuration C encompasses all functionality of the voting system with the exceptions noted below. This configuration is comprised of a subset of the voting system products with the specific purpose of demonstrating EVS6000's support for the Punjabi and Gujarati foreign languages, which are required for the ExpressVote XL system. This configuration only includes Electionware and the ExpressVote XL.

Test configuration:

- Electionware
- ExpressVote XL

Excluded hardware:

- ExpressVote Marker (HW v1.0)
- ExpressVote Marker/Tabulator (HW v2.1)
- ExpressTouch
- DS200
- DS450
- DS850

Excluded functionality:

- Open Primary
- Reviewer or Judges Initials boxes
- Multi-card ballot support
- Massachusetts Group Vote
- Universal Primary Contest
- Multiple Target Cross Endorsement

1.8.2 System Overview

This section provides a description of the scope of **ES&S EVS 6.0.0.0** voting system and components.

The **ES&S EVS 6.0.0.0** voting system is composed of software applications, central count location devices and polling place devices with accompanying firmware, and COTS hardware and software. In addition to the voting system components, this documentation references ancillary products that are not required to be part of the certified system; however, these components were used to facilitate testing and demonstrate system interoperability.

1.8.2.1 Electionware®

Electionware election management software is an end-to-end election management software application that provides election definition creation, ballot formation, equipment configuration, result consolidation, adjudication and report creation. **Electionware** is composed of five software groups: Define, Design, Deliver, Results and Manage.

1.8.2.1.1 Manage

The Manage group is used to add jurisdictions and users, customize labels, set password policies, and set election code strength.

1.8.2.1.2 Define

The Define group is used to input critical data for the election. The Define group modules are Home, Capture, and Element Library.

Home Module

The Home module is where election management, template management, and equipment selection options take place. New elections are created within the Home module as well. Use the Create New Election feature to create a new election, give it a name, and set some basic parameters. A county must be selected to create an election. Enter the election information. This includes data about the jurisdiction and jurisdiction ID (such as county number), the election type (i.e. general, primary), any alternate names/IDs, and the rules profile (state-specific rules that apply to this election).

Existing elections created in **Electionware** will appear under the Home module and can be reopened from here for editing and management. Additional functionality includes backing up, restoring, and deleting elections.

Capture Module

The Capture module is where the election data is entered. Items such as languages, audio files, precincts, districts, contests, candidates, and ballot sets are in this module.

Element Library Module

The Element Library module is where electronic elements (such as system translations, audio and graphics, and equipment screen definitions) are managed and customized. These features include both system files (instructional text and audio displayed/played for the user) and screen graphics.

1.8.2.1.3 Design

The Design group is for designing ballot and audio elements for an election. The Design group modules are Paper Ballot, Touch Screen, and Accessible Ballot.

Paper Ballot Module

The Paper Ballot module incorporates the data in your election database (created in the Capture module) with finished ballot layouts. Paper Ballot can produce four distinct ballot layout types, depending on the needs of your jurisdiction: Column Portrait, Grid-Landscape, Grid-Portrait, Paper Flexible Grid.

Electionware employs ballot standards, which are supported by **ES&S EVS 6.0.0.0**, as follows:

- Supports the following paper sizes:
 - 8.5" x 11"
 - 8.5" x 14"
 - 8.5" x 17"
 - 8.5" x 19"

Electionware employs and supports the activation card paper standards as follows:

- Supports the following activation/**vote summary card** paper sizes:
 - 4.26" x 11"
 - 4.26" x 14"
 - 4.26" x 17"
 - 4.26" x 19"

Touch Screen Ballot Module

The Touch Screen Ballot module is used to format machine ballot display options that support multiple touchscreen layout sizes.

Accessible Ballot Module

The Accessible Ballot module is used to format and manage display options and ADA audio settings, and validate data before generating election files for ES&S accessible voting equipment.

1.8.2.1.4 Deliver

The Deliver group is used to configure equipment, package election data and print ballots on demand. The Deliver group modules are Configure, Package, and Print.

Configure Module

In the Configure module, users can manage election equipment and security settings and generate election files for the **ES&S EVS 6.0.0.0** voting system components.

Package Module

The Package module is for creating Qualification, Election, and Reporting media (election definition files saved on an **ES&S** portable flash drive or compact flash card).

Print Module

Use the Print module to print extra ballots for individual polling places.

1.8.2.1.5 Results

The Results group in **Electionware** contains the post voting capability to process, review, and report election results data from the tabulation media.

This group includes all of the tools used for loading results, machine logs, cast vote records, and ballot images; creates the results reports; ballot review and adjudication; and write-in review and management.

After the election, the Reporting module can display or export detailed status information about individual flash drives, and produce machine log reports. It can clear loaded results files, in order to delete test data or to start the loading process over.

The Results group is capable of tabulating and reporting results for any election defined in the **ES&S EVS 6.0.0.0** voting system.

1.8.2.2 ExpressVote XL™

ExpressVote XL is a "paper-based voting system" that incorporates a ballot marking device and scanner into a single unit, which in addition to retaining all feature functionality of the **ExpressVote HW2.1**, the **ExpressVote XL** may be configured as a tabulator.

When configured as a tabulator, the **ExpressVote XL** uses a flash drive that is used to open each terminal for voting (open polls) and close the terminal from voting (closing polls); called the master media device. The master media tracks the terminals it is used to open and is used to generate the consolidated Zero Totals report for those terminals.

If the **ExpressVote XL** is programmed as a tabulator and in the rolling kiosk configuration, the printed vote summary card is internally scanned and tabulated to a USB flash drive. Otherwise, a separate **ES&S** tabulator may process the vote summary card.

1.8.2.3 ExpressTouch™

ExpressTouch Electronic Universal Voting System (**ExpressTouch**) is a DRE voting system which supports electronic vote capture for all individuals at the polling place. Voters navigate ballot selections using the touch screen, detachable UVC keypad or ADA support peripheral such as a sip and puff device or two-position switch, with screen prompts, symbols and ballot audio. Screen controls meet all applicable guidelines for size and readability. The **ExpressTouch** includes a mandatory vote summary screen that requires voters to confirm or revise selections prior to casting their votes.

1.8.2.4 ExpressVote® Hardware 1.0

ExpressVote Universal Voting System Hardware 1.0 (ExpressVote HW1.0) is a paper based ballot marking polling place universal voting device that provides digital vote capture through a touch screen or accessibility interface using a detachable ADA keypad or ADA support peripheral such as sip-and-puff device or two-position switch.

The **ExpressVote HW1.0** has four configurations: ADA table, tabletop, voting booth, or rolling kiosk. The rolling kiosk is easily positioned for seated or standing voters and can optionally provide QR code scanning, report printing, and a secure card container. The QR code can be scanned by ExpressVote for review and validation of vote selections

When the voter selections are complete a vote summary screen requires voters to confirm or revise their selections prior to printing. Once confirmed, vote selections are printed in both human and machine-readable formats on the vote summary card. Vote selections are not stored in memory after the vote summary card is ejected. A separate **ES&S** tabulator may process the printed vote summary card.

1.8.2.5 ExpressVote® Hardware 2.1

ExpressVote Universal Voting System Hardware 2.1 (ExpressVote HW2.1) is a "paper-based voting system" that incorporates a ballot marking device and scanner into a single unit, which in addition to retaining all feature functionality of the **ExpressVote HW1.0**, the **ExpressVote HW2.1** may be configured as a tabulator and provides the added, optional capability of tabulating printed vote summary cards.

When configured as a tabulator, the **ExpressVote HW2.1** uses a flash drive that is used to open each terminal for voting (open polls) and close the terminal from voting (closing polls); called the master media device. The master media tracks the terminals it is used to open and is used to generate the consolidated Zero Totals report for those terminals.

If the **ExpressVote HW2.1** is programmed as a tabulator and in the rolling kiosk configuration, the printed vote summary card is internally scanned and tabulated to a USB flash drive. Otherwise, a separate **ES&S** tabulator may process the vote summary card.

1.8.2.6 DS200®

DS200 is a polling place paper-based voting system, specifically a digital scanner and tabulator that simultaneously scans the front and back of a paper ballot and/or vote summary card in any of four orientations for conversion of voter selection marks to electronic Cast Vote Records (CVR). Once the CVRs are stored, they can be transferred into **Electionware** software for vote tabulation, adjudication and reporting of election results. After the voter marks a paper ballot either manually or digitally, their ballot is inserted into the unit and tabulated to a USB flash drive and internal vote counter.

If issues are detected, the system may provide a warning or flag the scanned ballot for review. Some examples include overvotes, undervotes, if so configured, damaged ballots, and ballots not configured for the device or election.

Once the ballot is tabulated, the ballot is dropped into an integrated ballot box. The scanned voter selections are stored to a USB flash drive. The USB flash drive is removable from the system for transport to a central election location where vote totals are consolidated for reporting.

An integrated printer prints zero reports prior to opening of pools, as well as log reports and polling place totals upon the official closing of the polls.

DS200 uses digital signatures, encryption, and security access codes to safeguard data.

1.8.2.7 DS450®

DS450 is a central scanner and tabulator that simultaneously scans the front and back of a paper ballot and/or vote summary card in any of four orientations for conversion of voter selection marks to electronic Cast Vote Records (CVR). Once the CVRs are stored, they can be transferred into **Electionware** software for vote tabulation, adjudication and reporting of election results.

The **DS450** sorts tabulated ballots into discrete output bins without interrupting scanning, based on pre-defined sort criteria, such as the ballot being unreadable, having write-ins, overvotes, undervotes, blank ballots or invalid election or ballot style ID. The DS450's ballot tracking feature enables the operator to rescan all ballots from the current stack or to manage the ballots in the current stack. The messages displayed on the touch screen and the LED lights on the front of the output bins walk the operator through the process of setting aside all properly scanned ballots and rescanning the rest. Optionally, this device may be configured to transmit tabulation results to the results server through a closed network connection rather than using physically transported media.

1.8.2.8 DS850®

DS850 is a central scanner and tabulator that simultaneously scans the front and back of a paper ballot and/or vote summary card in any of four orientations for conversion of voter selection marks to electronic Cast Vote Records (CVR). Once the CVRs are stored, they can be transferred into **Electionware** software for vote tabulation, adjudication and reporting of election results. The **DS850** sorts tabulated ballots into discrete output bins without interrupting scanning, based on pre-defined sort criteria, such as the ballot being unreadable, having write-ins, overvotes, undervotes, blank ballots or invalid election or ballot style ID.. Optionally, this device may be configured to transmit tabulation results to the results server through a closed network connection rather than using physically transported media.

1.8.2.9 Event Log Service (ELS)

ELS monitors and logs user's interactions with the Election Management System. Events that happen when a connection to the database is not available are logged to the Windows Operating System log through the Event Log Service.

1.8.2.10 Removable Media Service (RMS)

RMS is a utility that runs in the background of the Windows operating system. RMS reads specific information from any attached USB devices so that **ES&S** applications such as **ElectionWare** can use that information for media validation purposes. The service also provides functionality similar to the Safely Remove Hardware feature on the Windows system tray, allowing applications to eject media devices without user input.

1.8.3 Block Diagrams

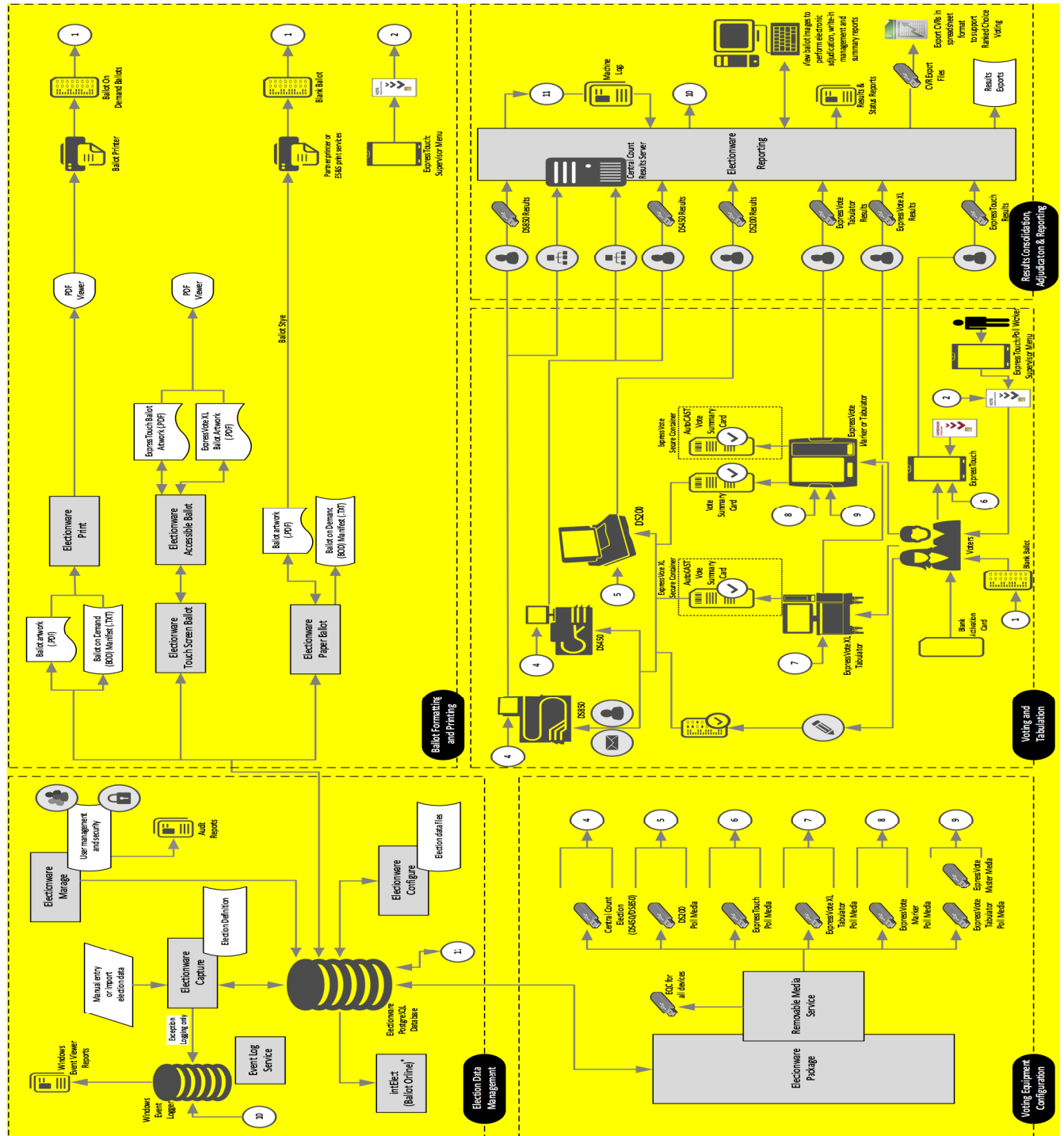

Figure 1: Voting System Overview – Test Configuration A

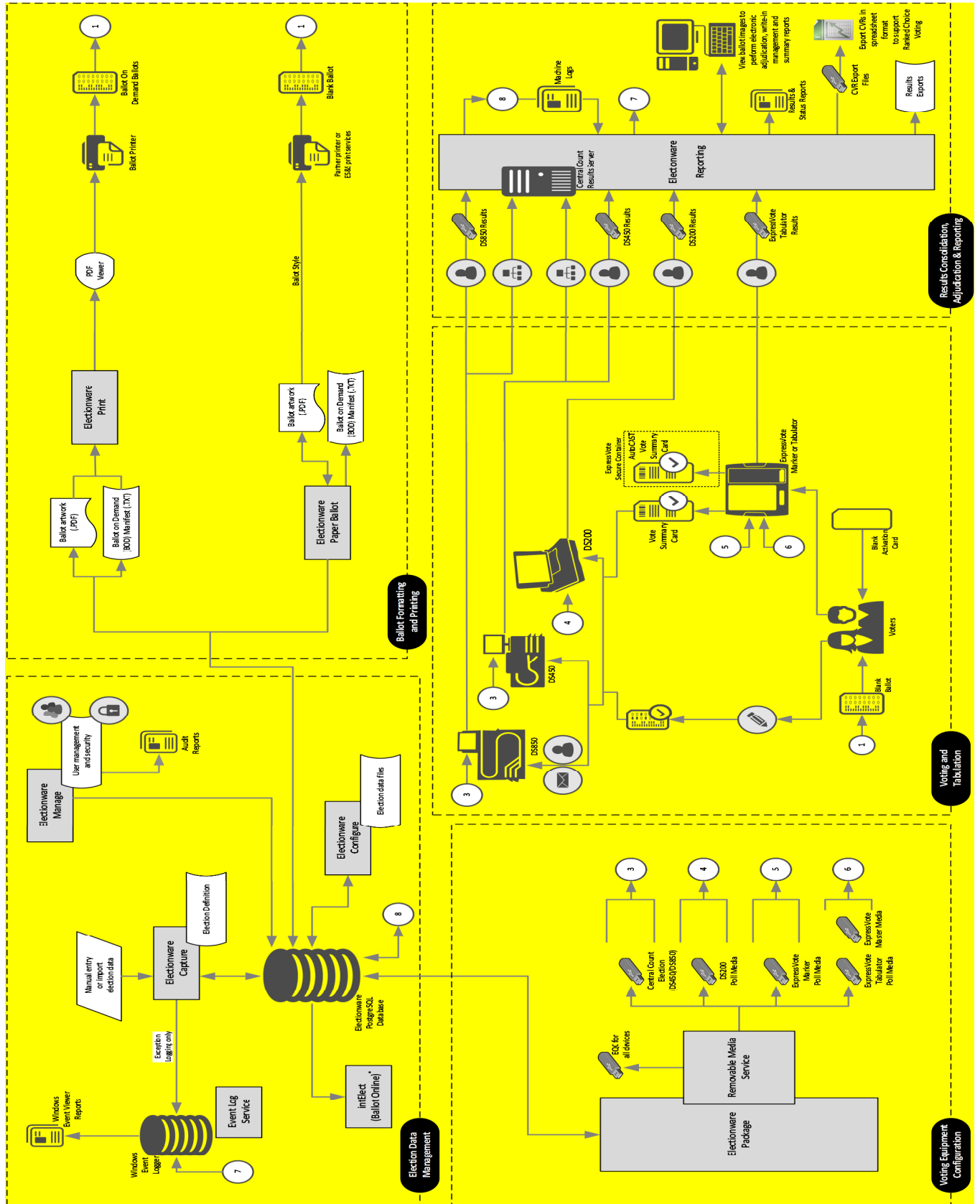

Figure 2: Voting System Overview – Test Configuration B

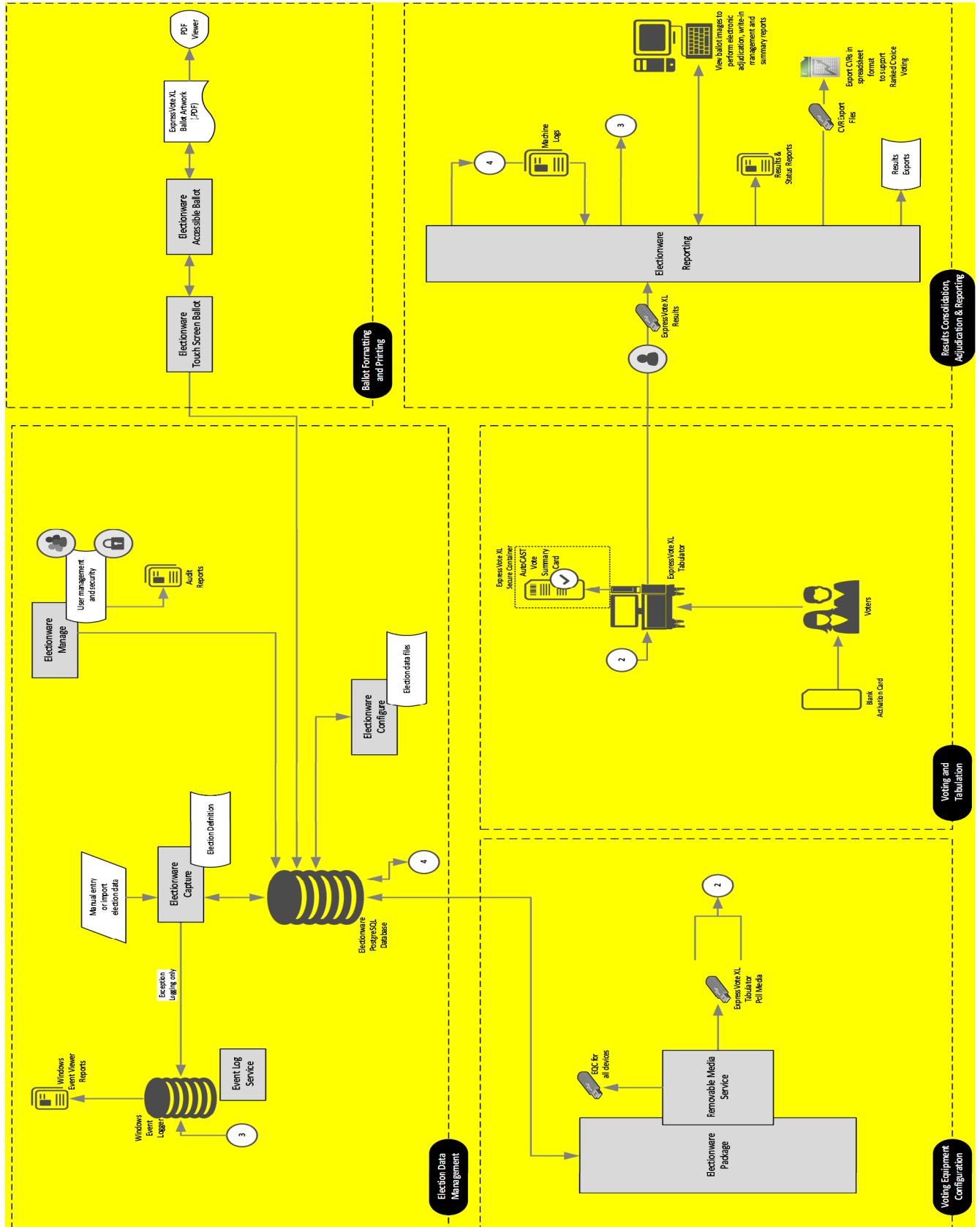

Figure 3: Voting System Overview – Test Configuration C

1.8.4 System Limits

This section details various limits within the **ES&S EVS 6.0.0.0** voting system. All documented limits will be reviewed and verified for accuracy.

- Max precinct allowed in an election: 9,900
- Max candidate allowed per election: 30,000
- Max contests allowed in an election: 30,000
- Max contests allowed per ballot style: 500 or number of positions on ballot
- Max candidate (ballot choices) allowed per contest: 230
- Max number of parties allowed in General Election: 75
- Max number of parties allowed in Primary Election: 30
- Max 'vote for' per contest: 230
- Max ballot styles: 15,000
- Max district types/groups: 25
- Max district of a given type: 250
- Max reporting groups: 14
- Electionware
 - Electionware Export Ballot Images function is limited to: 250 districts per export
 - Electionware supports certain language special characters as listed in the table below. Language special characters other than those supported may not appear properly when viewed on equipment displays or reports.

Language	Special Character
Spanish	Á, á, É, é, Í, í, Ñ, ñ, Ó, ó, Ú, ú, Ü, ü
French	À, à, Â, â, Æ, æ, Ç, ç, È, è, É, é, Ê, ê, Ë, ë, Î, î, Ï, ï, Ô, ô, OE, oe, Ù, ù, û, Ü, ü
German	Ä, ä, É, é, Ö, ö, Ü, ü, ß

- The Straight Party feature must not be used in conjunction with the Single or Multiple Target Cross Endorsement features.
- The paper ballot code channel, which is the series of black boxes that appear between the timing track and ballot contents, limits the number of available ballot variations depending on how a jurisdiction uses this code to differentiate ballots. The code can be used to differentiate ballots using three different fields defined as: Sequence (available codes 1-16,300), Type (available codes 1-30) or Split (available codes 1-18).
- For paper ballots, if Sequence is used as a ballot style ID, it must be unique election-wide and the Split code will always be 1. In this case the practical style limit would be 16,300.

- The ExpressVote activation card has a ballot ID consisting of three different fields defined as: Sequence (available codes 1-16,300), Type (available codes 1-30) or Split (available codes 1-18).
- The 'MasterFile.txt' and the 'Votes File.txt' do not support results for elections that contain multiple sheets or multiple ExpressVote cards per voter. These files can be produced using the Electionware > Reporting > Tools > Export Results menu option. This menu option is available when the Rules Profile is set to "Illinois".
- ExpressVote, Hardware 1.0
 - Secure Card Container Capacity: 300 vote summary cards
- ExpressVote, Hardware 2.1
 - Secure Card Container Capacity: 300 vote summary cards
- DS200
 - Storage limitation for write-in ballot images is 3,600 images
 - To successfully use the write-in report, ballots must span at least three vertical columns. Using two columns or fewer results in the write-in area being too large to print on the report tape.
 - Plastic Ballot Box Capacity
 - Main compartment: 1,250 ballots
 - Removable tote bin: 1,500 ballots
 - Auxiliary compartment: 100 ballots
 - Metal Ballot Box Capacity
 - Main compartment: 1,500 ballots
 - Write-in compartment: 1,500 ballots
 - Auxiliary compartment: 125 ballots
 - Collapsible Ballot Box Capacity
 - Main compartment: 3,000 ballots
 - Auxiliary compartment: 100 ballots
- DS450
 - Tray/Bin Capacity
 - Input tray 480
 - Output bin 480
 - Outstack bins 150
- DS850
 - Tray/Bin Capacity
 - Input tray 480

- Output bin 480
- Outstack bin 150
- ExpressTouch
 - ExpressTouch does not offer open primary support based on the ES&S definition of Open Primary, which is the ability to select a party and vote based on that party.
 - ExpressTouch does not support recall/retain contest pairs.
 - ExpressTouch does not support Massachusetts Group Vote.
 - ExpressTouch does not support Universal Primary Contest.
 - ExpressTouch does not support Multiple Target Cross Endorsement.
- ExpressVote XL
 - Secure Card Container Capacity: 300 vote summary cards
 - ExpressVote XL does not offer open primary support based on the ES&S definition of Open Primary, which is the ability to select a party and vote based on that party.
 - ExpressVote XL does not support recall/retain contest pairs.
 - ExpressVote XL does not support Massachusetts Group Vote.
 - ExpressVote XL does not support Universal Primary Contest.
 - ExpressVote XL does not support Multiple Target Cross Endorsement.
 - ExpressVote XL does not support Reviewer or Judges Initials boxes.
 - ExpressVote XL does not support multi-card ballots.
 - In a General election, one ExpressVote XL screen can hold 32 party columns if set up as columns or 16 party rows if set up as rows.
- Accessible equipment
 - Number of characters allowed on a single Write-In selection: 30

1.8.5 Supported Languages

The **ES&S EVS 6.0.0.0** voting system has declared support for English, Spanish, Chinese, Korean, Japanese, Hindi, Bengali, Vietnamese, Tagalog, Creole, Russian, French, Gujarati and Punjabi languages for this certification project.

1.8.6 Supported Functionality

The following standard VVSG functionality and manufacturer extensions are included in the voting system.

1.8.6.1 Voting Variations

The **ES&S EVS 6.0.0.0** supports the following voting variations:

- Closed primaries
- Open primaries
- Partisan offices
- Non-partisan offices
- Write-in voting
- Ballot rotation
- Straight party voting
- Cross-party endorsement
- Split precincts
- Vote for N of M
- Recall issues with options
- Provisional or challenged ballots

1.8.7 Excluded Requirements

In this section VVSG requirements are identified that do not pertain to the declared system being certified. The table below enumerates the requirements that will not be subject to verification for this project.

Excluded Requirements	Requirement Title
2.1.7.2.f	Primary presidential delegation nominations
2.1.7.2.m	Cumulative Voting
2.1.7.2.n	Ranked Choice Voting
3.2.1.c	General (biometric measures)
3.2.2.2.c.i	Telephone style handset or headphone to provide audio
4.1.4.2.c	Frames or Fixtures for Printed Ballots
7.5.2.a, b, c	Protection Against External Threats
7.5.3	Monitoring and Responding to External Threats
7.6	Use of Public Communications Networks
7.7	Wireless Communications
7.8	Independent Verification Systems
7.9	Voter Verifiable Paper Audit Trail Requirements

1.8.8 Additional Functionality/Requirements

As per 2005 VVSG, volume 2, section 3.2.2, review of the **ES&S EVS 6.0.0.0** System Functionality Description document resulted in SLI's determination that some functionality/requirements that are considered beyond the scope of the VVSG, but since they are in the declared system, will require review and verification.

VVSG related requirement (if applicable)	Feature
	EMS
2.1.2.b, 4.1.5.1.b	Electionware can configure the DS200 to accept or reject ballots based on whether or not Review Box and/or Judges Initials Boxes are required.
2.1.7.2	Electionware supports both NY and PA style cross-endorsements through the assigning of additional parties to a candidate in the candidate dialog.
2.3.3.1.d 4.1.5.1.d.ii	Electionware can configure the DS200 for ballot stamping write-ins.
2.3.1.2.e,f (2.1.1, 2.1.4, 2.1.5.1)	Electionware can configure the DS200 to display system health status in a QR two-dimensional barcode that can be scanned to pass the data back to a central administration site in preparation for opening the polls. A poll worker can take a picture of the code with their smartphone and use the smartphone-based scanning application to pass the data to a central administration site.
2.3.1.2.c 4.1.4.2.d.iv 4.1.5.1.d.ii	When the DS200 is configured on a metal ballot box that is equipped to optionally divert ballots into two compartments, Electionware can program the DS200 to optionally divert ballots into two compartments based on ballot criteria such as blank ballots and overvotes.
2.3.3.1.d 2.4.2	Electionware can configure the DS200 to print a report containing an image or "snippet" of the write-in entries from voters' ballots or vote summary cards.
	Electionware can configure the DS200 , DS450 and DS850 so that ballot images captured on the devices can be viewed in Electionware .
	Electionware can configure the DS200 , DS450 and DS850 so that ballots with write-ins can be filtered from other ballots when reviewed in Electionware .
	Electionware can configure the DS200 such that ballots containing write-ins can also be reviewed by displaying their images on-screen.
	Electionware can configure ExpressVote units to allow a voter to scan a barcode (printed or mobile device) to load their vote

VVSG related requirement (if applicable)	Feature
	selections done at home on a sample ballot..
	The Electionware Reporting module can be used to export decrypted ballot images for FOIA purposes.
	DS200
2.1.2.b	The DS200 may be configured to accept or reject ballots based on whether or not Review Box and/or Judges Initials Boxes are required.
2.1.7.2	The DS200 may be configured for cross party endorsement where a candidate may be associated with up to four different parties. Selection of any party associated with the candidate will result in that candidate receiving a vote.
2.3.3.1.d	The DS200 may be configured for ballot stamping of ballots with write-ins.
None	The DS200 is able to display system health status in a QR two-dimensional barcode that can be scanned to pass the data back to a central administration site in preparation for opening the polls. A poll worker can take a picture of the code with their smartphone and use the smartphone-based scanning application to pass the data to a central administration site.
2.3.1.2.c	The DS200 can be configured such that when paired to a metal ballot box that is equipped to optionally divert ballots into two compartments, ballots may be diverted based on ballot criteria such as blank ballots and overvotes.
2.3.3.1.d	DS200 can print a report containing an image or “snippet” of the write-in entries from voters’ ballots or vote summary cards. Images of ballot pages that contain write-ins can also be reviewed on screen after the polls have closed.
	Ballot images captured by the DS200 can be viewed in Electionware .
	The DS200 can be configured such that ballots containing write-ins can also be reviewed by displaying their images on-screen.
	ExpressVote HW1.0
2.1.7.2	ExpressVote HW1.0 can be configured to support cross party endorsement where a candidate may be associated with up to four different parties. Selection of any party associated with the candidate will result in that candidate receiving a vote.
	ExpressVote HW1.0 can be configured to allow a voter to scan a barcode (printed or mobile device) to load their vote selections done at home on a sample ballot to an ExpressVote session

VVSG related requirement (if applicable)	Feature
	using a barcode scanning device attached to the ExpressVote or integrated into the ExpressVote rolling kiosk. The selections the voter made will be presented to the voter on the ExpressVote summary screen. The voter will then be able to proceed with the ExpressVote session as normal (making/changing/confirming vote selections, printing selections, etc.).
	ExpressVote HW2.1
2.1.7.2	ExpressVote HW2.1 can be configured to support cross party endorsement where a candidate may be associated with up to four different parties. Selection of any party associated with the candidate will result in that candidate receiving a vote.
	ExpressVote HW2.1 can be configured to allow a voter to scan a barcode (printed or mobile device) to load their vote selections done at home on a sample ballot to an ExpressVote session using a barcode scanning device attached to the ExpressVote or integrated into the ExpressVote rolling kiosk. The selections the voter made will be presented to the voter on the ExpressVote summary screen. The voter will then be able to proceed with the ExpressVote session as normal (making/changing/confirming vote selections, printing selections, etc.).
2.4.2	When configured as a tabulator, the ExpressVote allows for the poll-level consolidation and reporting of votes cast.
	DS450
2.3.3.1.d 4.1.5.1.b.i	DS450 tabulators can be set to outstack or sort ballots for which the Review Box is marked or the Judges Initials Boxes are not properly completed. Election officials have the option to change these settings after the proper access code is provided and as the laws of the particular jurisdiction allow.
2.1.7.2	DS450 supports cross party endorsement where a candidate may be associated with up to four different parties. Selection of any party associated with the candidate will result in that candidate receiving a vote.
	Ballot images captured by the DS450 can be viewed in Electionware .
4.1.5.1.b.i	The DS450 can be configured to physically sort ballots containing write-ins and allow an option for these ballots to be counted or uncounted.

VMSG related requirement (if applicable)	Feature
	DS850
2.3.3.1.d 4.1.5.1.b.i	DS850 tabulators can be set to outstack or sort ballots for which the Review Box is marked or the Judges Initials Boxes are not properly completed. Election officials have the option to change these settings after the proper access code is provided and as the laws of the particular jurisdiction allow.
2.1.7.2	The DS850 supports cross party endorsement where a candidate may be associated with up to four different parties. Selection of any party associated with the candidate will result in that candidate receiving a vote.
	Ballot images captured by the DS850 can be viewed in Electionware .
4.1.5.1.b.i	The DS850 can be configured to physically sort ballots containing write-ins and allow an option for these ballots to be counted or uncounted.

1.9 Change Control and Configuration Management

The SLI project team follows a standard Change Control and Configuration Management (CM) process. This specifies the methods used by SLI to ensure changes are managed and controlled effectively and efficiently and defines the process for receipt, check-in, storage and disposition of hardware, source code, TDP and non-TDP documents.

It specifies the processes and procedures used by SLI to identify, monitor, and control versions of all of the stated EAC project deliverables, ensuring that the items are constantly and reliably managed throughout the entire duration of the engagement to ensure changes are managed and will not result in invalidated or wasted testing efforts.

A summary of these tasks includes:

- Receive TDP source code:
 - Delivery department will perform a code check-in on the server. Code is placed in the specific project's TDP folder with the delivery date and documentation of what was delivered.
 - Delivery department notifies TM of delivery via email.
 - TM will notify the SCR team, via email, the code is ready for review.

- TM will review the documentation of what was delivered to determine possible testing impacts.
- Source Code Reviewer updates status of delivered code as received, what code to compare it to (if this is not new code), where code has been placed, and who will do the review of the code.
- The code is checked out by the SCR who is responsible for the code review.
- When the code review is complete, the TM is notified.
- A peer review is done on the review and all discrepancies are verified and an official Discrepancy Report is sent to **ES&S**.
- If the SCR team determines the code does not meet the requirements of the 2005 VVSG, the SCR team will review code impacts with the TM.
- TM determines when code is ready for a Trusted Build. When it is, the TM sends approval for a Trusted Build to the Trusted Build team.
- Receive TDP documents:
 - Delivery department will perform a check-in of the documents on the server.
 - Documents are placed in the specific project's TDP folder with the delivery date.
 - Delivery department notifies TM of delivery via email.
 - TM assigns VTS personnel to perform the documentation review.
 - VTS personnel perform a PCA on the pertinent documentation.
 - A peer review is done on the VTS personnel's review, all discrepancies are verified and an official Discrepancy Report is sent to **ES&S**.
- Receive Hardware
 - The HW Specialist or designee checks in equipment that is delivered by **ES&S**.
 - Operational Status Checks are performed on all delivered hardware.
 - When the equipment comes back from the hardware lab testing, the HW Specialist checks in the equipment and verifies it's the same hardware that was sent to the lab.
 - The equipment is stored in a secure room with controlled access.
- Compliance/Trusted Build:
 - The TM assigns a Trusted Build team member to review the Compliance/Trusted Build procedures and perform the build.
 - Trusted Build team member follows build procedures exactly as written.
 - Trusted Build team member pulls the finalized source code from the specific folder where it was checked in.
 - Once build is complete, the Trusted Build team member provides the completed build to the SLI Delivery team to be checked in.
 - Trusted Build team member notifies the TM that the Compliance/Trusted Build is completed.
 - TM assigns appropriate VTS(s) to load the resulting applications/installs and begin testing.

- The VTS team performs appropriated installations, and begins testing.

2 PRE-CERTIFICATION TESTING AND ISSUES

*This section addresses any pre-certification testing that has been performed on the system under review. For this certification project, no previous testing has been performed on the **ES&S EVS 6.0.0.0** voting system, as it is a newly developed and as of yet un-fielded system.*

2.1 Evaluation of prior VSTL testing

No prior VSTL testing is pertinent to the **ES&S EVS 6.0.0.0** voting system, as it is a **New System**.

2.2 Evaluation of prior non-VSTL testing

No prior state or non-VSTL lab testing is pertinent to the **ES&S EVS 6.0.0.0** voting system, as it is a **New System**. Review of **ES&S** internal testing is performed during the FCA review.

2.3 Known Vulnerabilities

Review of the “Known Vulnerabilities” database, maintained by SLI, has provided 49 known vulnerabilities to previous **ES&S** systems, which are already accounted for in SLI’s Testing.

3 PHYSICAL CONFIGURATION AUDIT

3.1 TDP Documentation Analysis & Review

SLI will complete an assessment of the deliveries of the TDP, including Functional Requirements, Specifications, End-user documentation, Procedures, System Overview, Configuration Management Plan, Quality Assurance Program, and manuals for each of the required hardware, software and firmware components of the **ES&S EVS 6.0.0.0** voting system, in order to ensure that the documentation corresponds to the configuration and operation of the system. Any subsequent re-deliveries of the TDP items will be solely the result of fixes to discrepancies identified in the remaining FCA or PCA activities.

3.1.1 Document Review

SLI conducts a PCA review of all vendor traced documents submitted for review in the delivery of the **ES&S EVS 6.0.0.0** TDP. These include the following areas:

- System configuration overview
- System functionality description
- System hardware specifications

- Software design and specifications
- System test and verification specifications
- System security specifications
- User/system operations procedures
- System maintenance procedures
- Personnel deployment and training requirements
- Configuration management plan
- Quality assurance program

Each document included in the delivery of the voting system TDP is reviewed for compliance to the pertinent 2005 VVSG, Volume 2, Sections 2.2 through 2.13 and Volume 2, Section 6.6 requirements that are applicable to that document. Results and associated discrepancies of the documentation TDP review will be detailed in the final test report.

3.2 TDP Source Code Analysis & Review

3.2.1 Source Code Review

SLI has conducted a source code review of all proprietary source code, and modified COTS products, submitted in the delivery of the voting system TDP for compliance to the VVSG, version 2005, Volume 2, Section 6.6. The coding languages involved in **ES&S**'s applications include:

- C
- C++
- C#
- Java
- VB
- VB.net

Source code review tools utilized by SLI include:

- LocMetrics Line Counter: a commercial application used to determine the counts of executable and comment lines;
- Module Finder: an SLI proprietary application used to parse module names from C/C++ and VB code and populate the identified module names into the review documents;
- ExamDiff Pro: a commercial application used to compare revised code to previously reviewed code;
- Understand: a commercial application to perform automated review of source code.

Any subsequent re-reviews of source code will be the result of fixes to discrepancies identified in the FCA activities.

COTS operating systems and software used in the voting system will be verified as authentic and unmodified, otherwise reviewed as is applicable.

3.3 QA & CM Process Review

The review processes employed are designed to verify that the manufacturer not only has written processes and procedures in both the Quality Assurance and Configuration Management arenas, but that those processes and procedures are actually implemented within the **ES&S EVS 6.0.0.0** voting system development life cycle. QA and CM processes include software and hardware development processes that are used to produce the **ES&S EVS 6.0.0.0** voting system that is submitted for certification.

The QA portion of the review focuses on the review of the **ES&S** documented QA processes and policies, as well as the actual QA implementation and testing performed by **ES&S**. The scope of the testing performed is reviewed in order to verify that **ES&S** has complied with all applicable VVSG requirements. SLI reviews the test case design documents and data as provided by **ES&S**. In evaluating each module, with respect to flow control parameters and data on both entry and exit, SLI assesses discrepancies between the Software Specifications and the test case design. Surveys addressing Quality Assurance aspects as implemented by **ES&S** will be sent to **ES&S** QA personnel. Additionally, interviews of key Quality Assurance staff may be conducted to verify that the QA processes and procedures are known, understood and implemented by the appropriate personnel within the **ES&S** organization. The interviews will be conducted if issues are seen with either project artifacts or survey responses.

The CM portion of the review focuses on the review of the **ES&S** documented CM processes and policies, as well as the **ES&S** organization's understanding and implementation of the declared configuration management processes, procedures and policies. Initial deliverables will be reviewed against all pertinent CM processes employed by **ES&S**. Any and all subsequent deliveries will also be reviewed to determine that appropriate processes are employed. Surveys addressing Configuration Management aspects as implemented by **ES&S** will be sent to **ES&S** CM personnel. Additionally, interviews of pertinent staff, with regard to configuration management, may be conducted to verify that processes, procedures and policies are known, understood and implemented within the **ES&S** organization. The interviews will be conducted if issues are seen with either project artifacts or survey responses.

3.4 Compliance/Trusted Build

A Compliance Build will be conducted prior to SLI's formal test execution and will be completed on site at SLI's facility or a secure lab at the vendor's facility approved by SLI. The Trusted Build will be conducted prior to SLI's final test execution and will be completed on site at SLI's facility or a secure lab at the vendor's facility approved by SLI. SLI will use its approved standard lab procedure that details the processes for controlling, managing, and conducting the Trusted Build. This process includes the following:

- Preparation for the Compliance/Trusted Build - Obtaining and reviewing **ES&S**'s procedure for constructing the build platform, verifying the target build platform, and acquiring and verifying the necessary materials.
- Execution of the Compliance/Trusted Build – SLI will perform the Compliance/Trusted Build by using the step-by-step build procedure, as provided by **ES&S** to create a pristine build environment. SLI records and ascertains the following items throughout the build process:

- Build environment images at various key points
 - Build environment and file hashes at various key points
 - Build environment hardware characteristics
 - Build results from code compilation and file hashes
 - Final software install files and file hashes
- Deliverables to Testing – Upon completion of the Trusted Build, certain items are sent to the SLI test group. The final result will be media containing the following:
 - Final software install files
 - Hash values to validate install files
 - Final Record Keeping and Archiving Procedures – At the conclusion of the Trusted Build process, SLI completes all final record keeping and archiving procedures at SLI's facility. This record keeping includes any unique identifiers, results of the build with version numbers and dates and descriptions of all hashes and images in the repository.

4 MATERIALS REQUIRED FOR TESTING

Any materials that are used in an election cycle must be provided to SLI to facilitate testing of the voting system. This section outlines these materials that are required.

4.1 Software/Firmware

All software and firmware that is to be used by the declared voting system, whether directly or indirectly, in a production environment, must be validated during the certification process.

The following software/firmware is required for the execution of hardware, software, telecommunications, and security tests. This includes all supporting software such as operating systems, compilers, assemblers, application software, firmware, any applications used for burning of media, transmission of data or creation/management of databases.

4.1.1 Manufacturer Software/Firmware

The **ES&S EVS 6.0.0.0** voting system consists of the following software and firmware components:

- **Electionware** Election database creation, media programming and tally/reporting software
- **DS450** Central Tabulator firmware, Central Count scanner and tabulator
- **DS850** Central Tabulator firmware, Central Count scanner and tabulator
- **DS200** Precinct Tabulator firmware, Precinct scanner and tabulator
- **ExpressVote HW1.0** UVS firmware, Precinct Universal Voting System
- **ExpressVote HW2.1** UVS firmware, Precinct Universal Voting System and/or tabulator
- **ExpressVote HW1.0 Previewer** ballot preview software

- **ExpressVote HW2.1 Previewer** ballot preview software
- **ExpressVote XL** UVS firmware, Precinct Universal Voting System and tabulator
- **ExpressTouch** UVS firmware, Precinct Universal Voting System
- **Event Log Service (ELS)** software service monitoring user's interactions with the Election Management System
- **Removable Media Service (RMS)** software service supporting election media programming

Note: Versions for each will be available after execution of the Trusted Build, and will be listed in the Test Report.

Table 3 – ES&S EVS 6.0.0.0 Software/Firmware

Application	Version
Electionware – Client/Server	5.0.0.0
Event Log Service	1.6.0.0
Removable Media Service	1.5.0.0
ExpressVote HW2.1 Previewer	2.4.0.0
ExpressVote HW1.0 Previewer	1.5.0.0
DS200	2.17.0.0
DS850	3.1.0.0
DS450	3.1.0.0
ExpressVote XL	1.0.0.0
ExpressTouch	1.0.0.0

4.1.2 COTS Software/Firmware

This section details the COTS software and firmware utilized within the **ES&S EVS 6.0.0.0** voting system.

Table 4 – COTS Software/Firmware

Manufacturer	Application	Version
Microsoft Corporation	Window 7 Professional	SP-1 (64-bit)
Microsoft Corporation	Windows Server 2008	R2, SP-1 (64-bit)
Microsoft Corporation	WSUS Microsoft Windows Offline Update Utility	10.9.2
Symantec	Symantec Endpoint Protection	14.0.0 (64-bit)
Symantec	Symantec Endpoint Protection Intelligent Updater (File-Based Protection)	20170523-003-v5i64.exe
Symantec	Symantec Endpoint Protection Intelligent Updater (Network-Based Protection)	20170522-011-IPS_IU_SEP.exe

Manufacturer	Application	Version
Symantec	Symantec Endpoint Protection Intelligent Updater (Behavior-Based Protection)	20170516-001-SONAR_IU_SEP.exe
Cerberus	Cerberus FTP Server – Enterprise	8.0.12 (64-bit)
Adobe	Adobe Acrobat Standard	XI
Microsoft Corporation	Visual C++ Redistributable	vc_redist.x64.exe (64-bit) vc_redist.x86.exe (86-bit)

4.1.3 Additional Supporting Test Software

This section outlines any and all test specific software that will be used by SLI in the certification campaign.

Table 5 – Additional Supporting Test Software

Manufacturer	Application	Version
Riverbed	WireShark	1.10.6
<u>LocMetrics</u>	<u>LocMetrics Line Counter</u>	2007
SLI Compliance	<u>Module Finder</u>	1.0
Prestosoft	<u>ExamDiff Pro</u>	3.0
Scitools	<u>Understand</u>	4.0

4.2 Equipment

The following equipment is required for the execution of the hardware, software, telecommunications, and security tests. This includes system hardware, general purpose data processing and communications equipment, and any test instrumentation required.

4.2.1 ES&S EVS 6.0.0.0 Equipment

The following manufacturer equipment will be used in testing:

Table 6 – ES&S EVS 6.0.0.0 Equipment

Hardware	Model
ExpressVote Universal Voting System	HW1.0
ExpressVote Universal Voting System	HW2.1
DS200	1.2
DS200	1.3
DS450	1.0
DS850	1.0
ExpressVote XL Full-Faced Universal Voting	1.0

Hardware	Model
System	
ExpressTouch Electronic Universal Voting System	1.0
ExpressVote Rolling Kiosk	98-00049
ExpressVote Voting Booth	87001
ExpressVote ADA Table	87031
DS200 Collapsible Ballot Box	N/A
DS200 Plastic Ballot Box	57521
DS200 Metal Ballot Box	N/A
DS200 Tote Bin	00074
DS450 Cart	3002
DS850 Cart	6823
Universal Voting Console	N/A
Tabletop Easel	N/A
ExpressTouch Booth	N/A

4.2.2 COTS Equipment

The following COTS equipment will be used in testing:

Table 6 – COTS Equipment

Manufacturer	Hardware	Model	Operating System
Innodisk	USB EDC H 2SE (1GB)	DEEUH 1-01GI72AC1SB (for EV HW1.0)	N/A
Innodisk	USB EDC H 2SE (16GB)	DEUH1-16GI72AC1SB (for EV HW2.1)	N/A
Delkin Devices	USB Embedded 2.0 Module (16GB)	MY16MGFSY-RA000-D	N/A
Symbol	Scanner (External)	DS9208	N/A
Zebra Technologies	Scanner (Integrated)	DS457-SR20009	N/A
OKI	Audit Printer	Microline 420	N/A
Dell	Report Printer	S2810dn	N/A
OKI	Report Printer	B431DN B431D	N/A
Tripp Lite	Spike Cube	SPIKECUBE	N/A
APC	Backup power supply (Uninterruptible Power Supply)	Back-UPS Pro 1500 Back-UPS RS 1500	N/A

Manufacturer	Hardware	Model	Operating System
Various (EMS Networked or Standalone configuration)	<ul style="list-style-type: none"> • Processor: Dual Core • RAM: 4 GB, 8 GB recommended • Hard Disk: 150 GB • Keyboard • Mouse • Monitor: 1280x800 resolution • Monitor – ExpressVote XL (Monitor needed for programming election for EV XL) 1920x1080p resolution • CD/DVD reader: 16x min • 2 USB ports: 2.0 min • Report Printer: w/printer control language driver 	N/A	Windows 7 Professional, SP-1 (64-bit)
Various (EMS Networked server configuration)	<ul style="list-style-type: none"> • Processor: Dual Core or Quad Core • RAM: 4 GB, 8 GB recommended • Hard Disk: 150 GB or 320 GB • Keyboard • Mouse • Monitor: 1280x800 resolution • Monitor – ExpressVote XL Program Your Own: 1920x1080p resolution • CD/DVD reader: 16x min • 2 USB ports: 2.0 min • Report Printer: Network printer w/printer control language driver • Ethernet Port • Back up power supply: 865 Watts / 		Windows Server 2008 R2, SP-1 (64-bit)

Manufacturer	Hardware	Model	Operating System
	1500 VA output capacity • Network Switch: 1 GB throughput		
Delkin	USB Flash Drive: 512 MB, 1 GB, 2 GB, 4 GB, 8 GB	N/A	N/A
AVID	Headphones	86002	N/A
Seiko Instruments	Thermal Printer	LTPD-347B	N/A
NCR / Nashua	Paper Roll	2320	N/A
Delkin	Compact Flash Memory Card: 1 GB max	N/A	N/A
Delkin	Compact Flash Memory Card Reader/Writer	6381	N/A
Delkin	CFAST Card, 4 GB	N/A	N/A
Lexar	CFAST Card Reader/Writer	LRWCR1TBNA	N/A
CardLogix	Smart Card	CLXSU128KC7 / AED C7	N/A
SCM Microsystems	Smart Card Writer	SCR3310	N/A
Fujitsu	Thermal Printer	FTP-62GDSL001FTP-63GMCL153	N/A

4.3 Test Materials

The following test materials are required for the performance of testing including, as applicable, test ballot layout and generation materials, test ballot sheets, test ballot cards and control cards, standard and optional output data report formats, and any other materials used in testing.

- Ballots and blank ballot grade paper
- Activation cards
- Ballot pens
- Printer paper rolls

4.4 Deliverable Materials

The following are documents and materials to be delivered as a part of the **ES&S EVS 6.0.0.0** voting system.

Document	Version
System Overview	1.3
System Functionality Description	1.0
DS200 Operator's Guide	1.0
DS450 Operator's Guide	1.0
DS850 Operator's Guide	1.0
EVS Event Log Service User's Guide	1.0
Electionware Vol. I: Administrator Guide	1.0
Electionware Vol. II: Define User Guide	1.0
Electionware Vol. III: Design User Guide	1.0
Electionware Vol. IV: Deliver User Guide	1.0
Electionware Vol. V: Results User Guide	1.0
Electionware Vol. VI: Appendices	1.0
ExpressTouch Operator's Guide	1.0
ExpressVote Operator's Guide (HW1.0)	1.0
ExpressVote Operator's Guide (HW2.1)	1.0
ExpressVote XL Operator's Guide	1.0
Requirements of the 2005 VVSG Trace to Vendor Testing	1.0
Requirements of the 2005 VVSG Trace to Technical Data Package	1.0
DS200 Hardware Specification HW 1.2	3.4
DS200 Hardware Specification HW 1.3	4.5
DS450 Hardware Specification	1.6
DS850 Hardware Specification	1.6
ExpressTouch Hardware Specification	1.0
ExpressVote Hardware Specification HW1.0	3.7
ExpressVote Hardware Specification HW2.1	1.1
ExpressVote XL Hardware Specification	1.0
Approved Parts List - DS200 v1.2	1.0
Approved Parts List - DS200 v1.3	1.2
Approved Parts List - DS450	1.1
Approved Parts List - DS850	1.3
Approved Parts List - ExpressTouch v1.0	1.0
Approved Parts List - ExpressVote v1.0	2.1
Approved Parts List - ExpressVote v2.1	2.1
Approved Parts List - ExpressVoteXL v1.0	1.0
System Development Program	1.4
ES&S Coding Standards	1.3
License Agreements for Procured Software	1.1
DS200 – Software Design Specification	1.0
DS450 – Software Design Specification	1.0
DS850 – Software Design Specification	1.0

Document	Version
Electionware – Software Design Specification	1.0
Electionware – PostgreSQL Entity Descriptions	N/A
Event Log Service – Software Design Specification	1.0
ExpressTouch Software Design Specification	1.0
ExpressVote (HW1.0) Software Design Specification	1.0
ExpressVote (HW2.1) Software Design Specification	1.0
ExpressVote XL Software Design Specification	1.0
System Test Plan	1.0
Usability Test Report: DS200 Precinct-Based Scanner and Tabulator	N/A
Quality Assurance Test Cases - DS200	1.0
Quality Assurance Test Cases - DS450	1.0
Quality Assurance Test Cases - DS850	1.0
Quality Assurance Test Cases - Electionware: Manage	1.0
Quality Assurance Test Cases - Electionware: Define	1.0
Quality Assurance Test Cases - Electionware: Design	1.0
Quality Assurance Test Cases - Electionware: Deliver	1.0
Quality Assurance Test Cases - Electionware: Results	1.0
Quality Assurance Test Cases - ExpressLink	1.0
Quality Assurance Test Cases - ExpressTouch	1.0
Quality Assurance Test Cases - ExpressVote HW1.0	1.0
Quality Assurance Test Cases - ExpressVote HW2.1	1.0
Quality Assurance Test Cases - ExpressVote XL	1.0
Quality Assurance Test Cases - Field Limits	1.0
Quality Assurance Test Cases - Integration	1.0
Usability Test Report: ExpressTouch Electronic Universal Voting System	N/A
Usability Test Report: ExpressVote Universal Voting System (HW1.0)	N/A
Usability Test Report: ExpressVote Universal Voting System (HW2.1)	N/A
Usability Test Report: ExpressVote XL Full-Faced Universal Voting System	N/A
EMS Client Workstation Secure Setup & Configuration Guide	1.0
EMS Server Secure Setup & Configuration Guide	1.0
Standalone EMS Workstation Secure Setup & Configuration Guide	1.0
Voting System Security Specification	1.0
Security Script Description	1.0
Verification Procedure: DS200 Precinct Scanner and Tabulator	1.0
Verification Procedure: DS450 High-Throughput Scanner & Tabulator	1.0
Verification Procedure: DS850 High-Speed Scanner & Tabulator	1.0
Verification Procedure: Election Management System Workstation and Server	1.0

Document	Version
Verification Procedure: ExpressTouch	1.0
Verification Procedure: ExpressVote Hardware 1.0	1.0
Verification Procedure: ExpressVote Hardware 2.1	1.0
Verification Procedure: ExpressVote XL	1.0
Verification Procedure: Verification PC Setup	1.0
Validation File List: DS200	1.0
Validation File List: DS450	1.0
Validation File List: DS850	1.0
Validation File List: Event Log Service	1.0
Validation File List: ExpressTouch	1.0
Validation File List: ExpressVote HW1.0	1.0
Validation File List: ExpressVote HW2.1	1.0
Validation File List: ExpressVote XL	1.0
Validation File List: ExpressVote HW1.0 Previewer	1.0
Validation File List: ExpressVote HW2.1 Previewer	1.0
Validation File List: Electionware	1.0
Validation File List: Removable Media Service	1.0
DS200 Maintenance Manual	1.0
DS450 Maintenance Manual	1.0
DS850 Maintenance Manual	1.0
ExpressTouch Maintenance Manual	1.0
ExpressVote Maintenance Manual (HW1.0)	1.1
ExpressVote Maintenance Manual (HW2.1)	1.1
ExpressVote XL Maintenance Manual	1.0
Personnel Deployment and Training Program	1.0
Configuration Management Program	1.2
Technical Documentation Program	1.1
Manufacturing Quality Assurance Program	1.4
Software Quality Assurance Program	1.3
Ballot Production Guide for EVS	2.7
Conformity Statement: 2005 VVSG	N/A
COTS Production Implementation Plan	1.0
EAC Application Requirements Trace	N/A

5 TEST SPECIFICATIONS

The following are the specifications for testing to be conducted on **ES&S EVS 6.0.0.0** voting system. The specifications contain details on the focus of testing, configuration(s), and the functions to be tested.

5.1 Requirements

The **ES&S EVS 6.0.0.0** voting system will be tested to the approved 2005 VVSG requirements.

All requirements within the VVSG are verified against the **ES&S EVS 6.0.0.0** voting system unless noted otherwise in the “Excluded Requirements”, section 1.8.6.

To evaluate the system test requirements, each section of the EAC 2005 VVSG shall be analyzed to determine the applicable tests, EAC 2005 VVSG Volume I sections, as well as the accompanying strategy for evaluation, are described below:

- **Section 2: Functional Requirements** – The requirements in this section shall be tested during the FCA, utilizing the SLI test suites specially designed for the **ES&S EVS 6.0.0.0** voting system. The data input during these tests shall be the predefined election definitions.
- **Section 3: Usability and Accessibility** – The requirements in this section shall be tested during the Usability Test, utilizing SLI test suites developed to cover the applicable requirements of this section.
- **Section 4: Hardware Requirements** – The requirements in this section shall be tested and/or overseen by SLI personnel.
- **Section 5: Software Requirements** – The requirements in this section shall be tested during source code review, TDP review, and FCA. A combination of review and functional testing shall be performed to verify these requirements are met. The functional testing will occur if the source code review reveals potential areas of issue within the code that are not explicitly covered by the VVSG source code requirements. The functional test team will work with the SCR team to determine what testing will need to be done in order to verify no issue is resident within the inspected code.
- **Section 6: Telecommunication** – The requirements in this section shall be tested during source code review, FCA, and Security Tests, utilizing SLI test suites custom designed for the **ES&S EVS 6.0.0.0** voting system.
- **Section 7: Security Requirements** – The requirements in this section shall be tested during source code review, FCA, and Security Tests, utilizing SLI test suites custom designed for the **ES&S EVS 6.0.0.0** voting system.
- **Section 8: Quality Assurance (QA) Requirements** – The requirements in this section shall be tested throughout the test campaign via various methods. The TDP review shall be performed on **ES&S** QA documentation to determine compliance to EAC 2005 VVSG requirements and the requirements stated in the **ES&S** QA Program document. All source code shall be checked to ensure that proper QA documentation has been completed. All equipment received for initial testing and follow-up testing shall be checked against **ES&S**

documentation to ensure their QA process is being followed. SLI personnel will complete the requirements of EAC 2005 VVSG Vol. 2, Section 7, Quality Assurance Testing and Section 1.3.1.5, Focus of Vendor Documentation that requires SLI personnel to examine documents or conduct an external evaluation utilizing equipment, documents and support information provided by **ES&S** during the test campaign. SLI may also choose to interview **ES&S**'s QA staff for further evaluation.

- **Section 9: Configuration Management (CM) Requirements** – The requirements in this section shall be tested throughout the test campaign. The TDP review shall be performed on the **ES&S** configuration management documentation to determine EAC 2005 VVSG compliance and to further determine whether **ES&S** is following its documented CM requirements. Any discrepancies shall be formally reported to **ES&S** and the EAC. SLI personnel may conduct an audit of the **ES&S** CM Program at the **ES&S** facility, if deemed necessary.

5.2 Hardware Configuration and Design

The **ES&S EVS 6.0.0.0** as declared in the application for certification submitted to the EAC, consists of:

- An **Electionware** standalone workstation with minimum requirements of 150 GB hard disk, 8 GB of recommended memory and Dual Core processing speed.
- For network configuration, a networked workstation with minimum requirements of 150 GB hard disk, 8 GB of recommended memory and Dual Core processing speed. Additionally, the network configuration includes a server with minimum requirements of 320 GB hard disk, 4 GB of memory and Quad Core processing speed.
- The precinct level employs **ExpressTouch**, **ExpressVote HW1.0**, **ExpressVote HW2.1** and **ExpressVote XL** universal voting devices, and the **DS200** tabulator.
- The central count location employs the **DS450** and **DS850** tabulators.
- The consolidation, tally and reporting process employs the workstation with either a direct connect or a network printer.

5.3 Testing Strategies

This section looks at the voting system and the individual components in order to determine testing strategies at the component level as well as the system level.

5.3.1 How each Polling Place Device will be tested

- How the **ExpressVote HW1.0** will be tested
 - **ExpressVote HW1.0** will be tested and is applicable to Configuration A and Configuration B, first as an individual paper-based ballot marking device in order to verify that all declared functionality is present and working as documented, including functionality such as buttons, configurable settings, input fields, inputs, etc., with **Electionware** produced media and data, then as an integrated piece of the voting

system where it will accept user input instructions, prior to producing marked vote summary cards that mirror user intent.

-
- How the **ExpressVote HW2.1** will be tested
 - **ExpressVote HW2.1** will be tested and is applicable to Configuration A and Configuration B, first as an individual paper-based ballot marking device in order to verify that all declared functionality is present and working as documented, including functionality such as buttons, configurable settings, input fields, inputs, etc., with **Electionware** produced media and data, then as an integrated piece of the voting system where it will accept user input instructions, prior to producing marked vote summary cards that mirror user intent. It will also be tested as a paper based scanner to determine that it is able to read in and tabulate all applicable vote summary cards created by the EVS 6000 voting system, as well as producing all defined output data on the assigned USB flash drive, if configured as a tabulator.
- How **DS200** will be tested
 - **DS200** will be tested and is applicable to Configuration A and Configuration B, first as an individual paper-based scanner in order to verify that all declared functionality is present and working as documented, including functionality such as buttons, configurable settings, input fields, inputs, etc., then as an integrated piece of the voting system where it will accept **Electionware** produced media and data, then accept user filled out ballots as well as vote summary cards, prior to producing all defined output data on the assigned USB flash drive.
- How **ExpressTouch** will be tested
 - **ExpressTouch** will be tested and is applicable to Configuration A, first as an individual DRE in order to verify that all declared functionality is present and working as documented, including functionality such as buttons, configurable settings, input fields, inputs, etc., with **Electionware** produced media and data, then as an integrated piece of the voting system where it will accept user input instructions, prior to tabulating voter's choices. It will also produce all defined output data on the assigned USB flash drive.
- How **ExpressVote XL** will be tested
 - **ExpressVote XL** will be tested and is applicable to Configuration A and Configuration C, first as an individual paper-based ballot marking device in order to verify that all declared functionality is present and working as documented, including functionality such as buttons, configurable settings, input fields, inputs, etc., with **Electionware** produced media and data, then as an integrated piece of the voting system where it will accept user input instructions, prior to tabulating voter's choices. It will also be tested as a paper based scanner to determine that it is able to read in and tabulate all applicable vote summary cards created by the EVS 6000 voting system, as well as producing all defined output data on the assigned USB flash drive.

5.3.2 How each Application will be tested

- How **Electionware** will be tested
 - **Electionware** will be tested and is applicable to Configuration A, Configuration B and Configuration C, first as an individual component in order to verify that all declared functionality is present and working as documented, including functionality such as buttons, configurable settings, input fields, inputs, etc., then as an integrated piece of the voting system where it will output **Electionware** produced media and data, which will feed into **ExpressVote HW1.0, ExpressVote HW2.1, DS200, ExpressTouch, ExpressVote XL, DS450, DS850** and **Electionware Reporting**.
- How the **DS450** and **DS850** will be tested
 - **DS450** and **DS850** will be tested and is applicable to Configuration A and Configuration B, first as individual paper-based central scanners in order to verify that all declared functionality is present and working as documented, including functionality such as buttons, configurable settings, input fields, inputs, etc., then as an integrated piece of the voting system where it will accept **Electionware** produced media and data, then accept user filled out ballots as well as vote summary cards.
- How **Electionware Reporting** will be tested
 - **Electionware Reporting** will be tested and is applicable to Configuration A, Configuration B and Configuration C, first as an individual component in order to verify that all declared functionality is present and working as documented, including functionality such as buttons, configurable settings, input fields, inputs, etc., then as an integrated piece of the voting system where it will accept **Electionware** produced media and data, then accept media data from **ExpressVote HW2.1, DS200, ExpressTouch, ExpressVote XL, DS450** and **DS850**, prior to producing all defined reports and exports.

5.4 Software System Functions

The **ES&S EVS 6.0.0.0** voting system operations documentation has been reviewed in conjunction with the Supported Functionality Declaration provided by **ES&S**. Based on this review, the applicable system functions have been identified for testing. The following key areas of voting system functionality will be evaluated during test suite design.

5.4.1 Election Definition Creation

The Election Definition focus will target creation of contests, candidates, propositions, ballot formatting and instruction. All aspects of creating regional districts, jurisdictional parameters, grouping and displaying of associated election data will be analyzed and tested. In addition, the ability to support baseline election types, various other election types, voting variations and languages will be verified.

5.4.2 Pre-voting Aspects

Pre-voting aspects include pre-election preparatory, diagnostic, and election verification functions of a voting system. The focus will include device preparation, all required pre-voting tasks including the creation and handling of media for the purposes of installing election data onto voting devices, as well as the creation of physical ballot layouts and creation of any/all media used to hold/transfer election data, and verification of manufacturer recommended pre-voting tasks.

5.4.3 Voting Aspects – Polling Place

Polling place aspects include all required and additional supported voting functions, including HAVA compliant requirements. This area will focus on all aspects of election functions and capabilities at the polling place from opening of the polls through closing the polls.

5.4.4 Voting Aspects – Central Count

The focus of the central count functions is primarily the usage of scanners to scan large quantities of absentee ballots and passing each image to **Electionware Reporting** for interpretation of the voter's markings on the ballot and/or vote summary card.

5.4.5 Post-voting Aspects

This area will focus on all required election post-voting functions. This includes any additional supported election functions performed after closing the polls, device auditing, transmission, and reporting aspects of the voting system.

5.4.6 Error Messaging and Recovery

This area will focus on the system's ability to generate appropriate error messaging within each system component and the system's ability to recover from error conditions in order to proceed with all election functions.

5.4.7 Auditing

This area will focus on device and system level auditing capabilities and will verify at a minimum the required audit functionality. This includes audit trail capability throughout the life cycle of the voting system and audit log content requirements.

5.4.8 Security

Overall system and device level logical and physical security aspects will be tested. Physical security will focus on the areas of integrity (ballot box doors, locks and seals) and detection (compromised ballot box doors, locks or seals). Logical security will focus on the areas of access controls, accountability, confidentiality, and integrity. These logical security areas will be applied to the OS, Database, Network and Application entities used by the EMS, universal voting devices and tabulators used by the voting system under test.

5.5 Test Suite Design

5.5.1 Hardware Qualitative Examination Design

SLI will review all reports submitted by the manufacturer of previous testing conducted by acceptable hardware test labs, on the equipment contained in the **ES&S EVS 6.0.0.0** voting system. The results will be compared against the guidelines of the VVSG 2005, Section 4 to identify any additional testing required. In addition, SLI will create the following test suites to focus on Maintainability, Accessibility, and Usability of the voting system:

- **Accessibility** - Accessibility requirements for a voting system generally include both objective and observable requirements. In combination, the two types of requirements verify that the

voting system components are accessible to as many eligible voters as possible, including those that have a type of challenge that creates a need for assistance of some type. The voting systems should be self-contained such that the individual voter is able to cast their vote without assistance from another party. Accessibility calls for the voting system to take into account vision, varying degrees of vision, dexterity, mobility, aural issues, and speech and language proficiency. Accessibility will be tested and is applicable to Configuration A, Configuration B and Configuration C.

- **Maintainability** - Maintainability encompasses a range of maintenance actions that examine all scheduled and unscheduled events in place for preventing failures on all hardware devices. Testing verifies the ease with which maintenance actions can be performed based on the design characteristics of the equipment and software. Non-technical election workers are able to be made aware of the problem through the equipment and software's ability to correctly self-diagnose problems. Maintainability will be tested and is applicable to Configuration A, Configuration B and Configuration C.
- **Usability** – Usability is defined as a measure of the effectiveness, efficiency, and satisfaction achieved by a specified set of users with a given product in the performance of specified tasks. In the context of voting, the primary user is the voter, the product is the voting system, and the task is the correct recording of the voters' ballot selections. Testing is conducted to ensure voters are able to negotiate the process effectively, efficiently and comfortably according to the requirements dictated. Accessibility will be tested and is applicable to Configuration A, Configuration B and Configuration C.

5.5.2 Hardware Environmental Test Design

Hardware environmental testing is performed to verify conformance to Vol. 1, Section 4 of the VVSG 2005. Testing will be accomplished through a combination of testing performed by SLI and testing performed by subcontractor labs as listed in "Table 2 – Labs Performing Hardware Testing". Specific hardware test plans from the subcontractor labs are included in Attachments B and C.

5.5.3 Software Module Test Design and Data

Incorporating the manufacturer's software specifications, SLI will validate that all software/firmware components of the system adhere to expected flow control parameters and specifications for data input and output.

5.5.4 Software Functional Test Design and Data

SLI will prepare functional test modules using the operator/user procedures contained within ES&S's TDP. Functionality provided by the ES&S EVS 6.0.0.0 voting system is exercised in order to verify that each functional component performs as expected. Accept/reject criteria are based on requirements of the VVSG and the system specification documents provided within the TDP. As many of the individual functional components rely on preceding functionality within the system, SLI incorporates system level suites that employ modules that exercise the individual functional components of the system.

5.5.5 System-level Test Design

Testing of the voting system involves exercising the specific functions of each component of a voting system as well as the entire voting system. Testing will focus on the functionality of an election management system, the polling place devices, and devices required for communications and data loading, then will focus on functionality of the integrated voting system.

There are various types of testing. Table 8 - Types of Testing provides the descriptions of these kinds of tests and their associated benefit.

Table 8 - Types of Testing

Type of Testing	Description	Benefit
Nominal Conditions	Testing all nominal functional capabilities of all components of the voting system.	Nominal Conditions testing ensures that the voting system is tested against all elements.
Data Driven	This is testing that is based on the data that is used throughout the voting system. For example, if 'x' is input in a field, it would branch to a different part of the application than if 'y' was entered. The goal is to ensure that all branches get tested.	The tests verify that each unique data element can be accessed and used according to the voting system's user documentation. These test cases are based on the election data or vote data used and not the functional flow or work flow of the voting system.
Usability	The purpose of UI Testing is to test all of the screen and data elements that exist on each and every screen. SLI will verify responses to input, text syntax, error message content, and audit message input.	These tests verify every action will work that a user can perform on a screen. These tests will also verify that any screen or data element will not take the user by surprise.
Error Messaging and Recovery	Exercise system's ability to recover from hardware, software, and data errors.	Ensures that the system is able to successfully recover should there be a system or data error.
End-to-End	This is system testing in a true end-user environment following all pre-Election Day, Election Day, and post-Election Day voting rules and processes.	This is used to demonstrate that a system can be used to perform its job following the exact set of processes and steps that would be used by the target customer or end-user.
Regression	Testing that validates that existing functionality is unchanged with the introduction of new functionality and correction of defects.	This is used to verify that issues are corrected, and that no known issues have been introduced or uncovered.
Formal Execution	Final verification of the voting system in a true end-user environment, following all pre-Election Day, Election Day, and post-Election Day voting rules and processes.	Testing "for the record" that includes all aspects of the voting system, verifying that all VVSG requirements are met.

Type of Testing	Description	Benefit
Volume Test	Testing the voting system's response to conditions that range from processing more than the expected number of ballots/voters per precinct to processing more than the expected number of precincts to any other similar volume conditions.	Determine if there are limits to the voting system's ability to operate under conditions that tend to overload the system's capacity to process, store, and report data.
Stress Tests	Testing the voting system's responses to transient overload conditions by subjecting polling place devices to ballot processing at high volume rates.	Evaluates the voting system and software's response to hardware-generated interrupts and wait states.
Accessibility Test	Exercises system capabilities of features for voters with disabilities.	Validates that the voting system is tested against all applicable ADA and HAVA requirements for voters with disabilities.
Performance Tests	Tests accuracy, processing rate, ballot format, handling capability and other performance attributes specified by ES&S .	Performance testing ensures that the voting system meets all performance elements.

5.5.6 Software Functional Test Case Design

Each individual component of the voting system will be reviewed independently, such that all functionality present in the component is verified to work as documented, and that all functionality is appropriately documented. For the components that are able to be networked, this will be reviewed as well. This approach corresponds to the following functional testing to be done.

5.5.6.1 Electionware – Standalone workstation

All functionality present in **Electionware**, including those covered in the "System Review" and "Supported Functionality" sections above, is verified to work as documented, and that all functionality is appropriately documented.

This test covers **Electionware**, and will be tested and is applicable to Configuration A, Configuration B and Configuration C.

5.5.6.2 Electionware – Client/Server configuration

Testing of the client/server configuration, for **Electionware**, will be the focus of this testing, such that reliability of data consistency is verified.

This test covers **Electionware**, in a server and multi-workstation configuration, and will be tested and is applicable to Configuration A, Configuration B and Configuration C.

5.5.6.3 DS450 and DS850 – Standalone workstation

All functionality present in **DS450** and **DS850**, including that covered in "System Review" and "Supported Functionality" sections above, is verified to work as documented, and that all functionality is appropriately documented.

This test covers **DS450** and **DS850**, and will be tested and is applicable to Configuration A and Configuration B.

5.5.6.4 DS450 and DS850 – Client/Server configuration

Testing of the client/server configuration, for **DS450** and **DS850**, will be the focus of this testing, such that reliability of data consistency is verified.

This test covers **DS450** and **DS850**, in a server and multi-workstation configuration, and will be tested and is applicable to Configuration A and Configuration B.

5.5.6.5 Electionware Reporting – Standalone workstation

All functionality present in **Electionware Reporting**, including that covered in “System Review” and “Supported Functionality” sections above, is verified to work as documented, and that all functionality is appropriately documented.

This test covers **Electionware Reporting**, and will be tested and is applicable to Configuration A, Configuration B and Configuration C.

5.5.6.6 Reporting – Client/Server configuration

Testing of the client/server configuration, for **Electionware Reporting**, will be the focus of this testing, such that reliability of data consistency is verified.

This test covers **Electionware Reporting**, in a server and multi-workstation configuration.

5.5.6.7 DS200

All functionality present in **DS200** will be verified to work as documented, and that all functionality is appropriately documented.

This test covers **DS200**, and will be tested and is applicable to Configuration A and Configuration B.

5.5.6.8 ExpressTouch

All functionality present in **ExpressTouch** will be verified to work as documented, and that all functionality is appropriately documented.

This test covers **ExpressTouch**, and will be tested and is applicable to Configuration A.

5.5.6.9 ExpressVote HW1.0

All functionality present in **ExpressVote HW1.0** will be verified to work as documented, and that all functionality is appropriately documented.

This test covers **ExpressVote HW1.0**, and will be tested and is applicable to Configuration A and Configuration B.

5.5.6.10 ExpressVote HW2.1

All functionality present in **ExpressVote HW2.1** will be verified to work as documented, and that all functionality is appropriately documented.

This test covers **ExpressVote HW2.1**, and will be tested and is applicable to Configuration A and Configuration B.

5.5.6.11 ExpressVote XL

All functionality present in **ExpressVote XL** will be verified to work as documented, and that all functionality is appropriately documented.

This test covers **ExpressVote XL**, and will be tested and is applicable to Configuration A and Configuration C.

5.5.7 System-level Test Suite Design

System level test suites will include the following:

- **Election Validations** - Election suites are created to replicate each type of election that can be implemented by the **system**. Within the election types, pertinent voting variations that are applicable to that type of election will be validated and verified. Each suite will have a particular focus in order to test the voting system's implementation of a given requirement or set of requirements. Each test suite below is explained in terms of the components of the voting system that will be addressed.

- **GenVariation1**

Additional definition is added, with a focus on validating N of M voting, Partisan offices, Non-Partisan Offices, Straight Party Voting, Ballot Rotations, Ballot Formatting, precincts and districts, and Tally and Reporting functionality.

This test covers **Electionware**, **ExpressTouch**, **ExpressVote HW1.0**, **ExpressVote HW2.1**, **ExpressVote XL**, **DS200**, **DS450** and **DS850** as well as **Electionware Reporting**. Vote counts will be accumulated from **DS450** and **DS850**, **ExpressTouch**, **ExpressVote XL**, **ExpressVote HW2.1** and **DS200**.

This suite will be run and is applicable to Configuration A, Configuration B and Configuration C.

- **GenVariation2**

Additional definition is added, with a focus on validating Recalls, Cross-Party Endorsement, Provisional Ballots, and Write-Ins.

This test covers **Electionware**, **ExpressTouch**, **ExpressVote HW1.0**, **ExpressVote HW2.1**, **ExpressVote XL**, **DS200**, **DS450** and **DS850** as well as **Electionware Reporting**. Vote counts will be accumulated from **DS450** and **DS850**, **ExpressTouch**, **ExpressVote XL**, **ExpressVote HW2.1** and **DS200**.

This suite will be run and is applicable to Configuration A, Configuration B and Configuration C.

GenVariation3

Additional definition is added, with a focus on validating the accessibility features of the voting system (for example ATI usage, paddles, sip and puff, audio, visual adjustments), as well as items such as pre-vote capabilities.

This test covers **Electionware, ExpressVote HW1.0, ExpressVote HW2.1, DS200, ExpressTouch, ExpressVote XL, DS450 and DS850** as well as **Electionware Reporting**. Vote counts will be accumulated from **DS450 and DS850, ExpressVote HW2.1, ExpressTouch, ExpressVote XL, and DS200**.

This suite will be run and is applicable to Configuration A, Configuration B and Configuration C.

- PriClosed

This suite implements a Closed primary election definition utilizing four partisan parties.

This test covers **Electionware, ExpressTouch, ExpressVote HW1.0, ExpressVote HW2.1, ExpressVote XL, DS200, DS450 and DS850** as well as **Electionware Reporting**. Vote counts will be accumulated from **DS450 and DS850, ExpressVote HW2.1, DS200, ExpressTouch, ExpressVote XL, and DS200**.

This suite will be run and is applicable to Configuration A, Configuration B and Configuration C.

- PriOpen

This suite implements an Open Primary election definition utilizing four partisan parties.

This test covers **Electionware, ExpressVote HW1.0, ExpressVote HW2.1, DS200, DS450 and DS850** as well as **Electionware Reporting**. Vote counts will be accumulated from **DS450 and DS850, ExpressVote HW2.1, and DS200**.

This suite will be run and is applicable to Configuration B.

- Error Recovery - The VSTL will focus on Error Messaging and Recovery in key areas of the system identified from researching previous testing and voting system documentation to help identify potential failure points. Voting systems can be subject to various conditions, and when the system exceeds limitations, errors are typically found. The VSTL leverages its election experience and voting system knowledge to test the Error Messaging and Recovery of a voting system that has incurred errors caused by stressing the system. Testing of Error Messaging will focus on the appropriate error messages being generated in response to a specific error and content of the message. The testing of the voting system Error Recovery capability is incorporated into Stress testing in order to leverage the necessary range of performance impacts needed to generate system errors and force recovery.

This test covers **Electionware, ExpressVote HW1.0, ExpressVote HW2.1, DS200, ExpressTouch, ExpressVote XL, DS450 and DS850** as well as **Electionware Reporting**.

This suite will be run and is applicable to Configuration A, Configuration B and Configuration C.

- **Audit Content Validations** - Audit records are used to track what system functions have been executed, what data has been modified, as well as by who and when. Additionally, audit record data content can be a key factor in identifying system anomalies and providing assistance in troubleshooting system errors. In tandem with the System Audit Validation, analysis of a voting system is performed to determine strategic points of the system that require auditing, along with the content needed to accurately depict the machinations of the system for the given situation. Tests are incorporated either into Election Validation suites or specific Audit Validation suites, as needed, such that all related requirements are explicitly validated.

This test covers **Electionware, ExpressVote HW1.0, ExpressVote HW2.1, DS200, ExpressTouch, ExpressVote XL, DS450 and DS850** as well as **Electionware Reporting**.

This suite will be run and is applicable to Configuration A, Configuration B and Configuration C.

- **System Audit** – Election audit trails provide the supporting documentation for verifying the accuracy of reported election results. They present a concrete, indestructible archival record of all system activity related to the vote tally, and are essential for public confidence in the accuracy of the tally, for recounts, and for evidence in the event of criminal or civil litigation. This testing focuses on validating the system’s ability to provide audit capability throughout the entire voting system, including availability, generation, integrity, and accuracy of the system’s audit capability to ensure it meets the necessary requirements. Negative testing will be utilized to force the system into conditions that will trigger errors and verify the voting system captures those conditions.

This test covers **Electionware, ExpressVote HW1.0, ExpressVote HW2.1, DS200, ExpressTouch, ExpressVote XL, DS450 and DS850** as well as **Electionware Reporting**.

This suite will be run and is applicable to Configuration A, Configuration B and Configuration C.

- **Security Validations** - Test suites are created to validate and verify various aspects of system security at both the component level and the system level, as applicable. Each suite will have a particular focus to it, such that when executed successfully, a given requirement, or set of requirements, will be determined to have been successfully implemented by the voting system. Topics of Security review will include:

- Access Control

Access control testing verifies procedures and system capabilities that detect or limit access to system components in order to guard against loss of system integrity, availability, confidentiality, and accountability. This testing verifies that system resources such as data files, application programs and computer-related facilities and equipment are protected against unauthorized operation, modification, disclosure, loss or impairment. Unauthorized operations include modification of compiled or interpreted code, run-time alteration of flow control logic or of data, and abstraction of raw or processed voting data in any form other than a standard output report by an authorized operator.

This test covers **Electionware, ExpressVote HW1.0, ExpressVote HW2.1, DS200, ExpressTouch, ExpressVote XL, DS450 and DS850** as well as **Electionware Reporting**.

This suite will be run and is applicable to Configuration A, Configuration B and Configuration C.

- Software Security

Software security testing will be conducted to verify the installation procedures and ongoing foreign software detection mitigation abilities of the voting system in order to protect against the modification of the software and/or the insertion of malicious software during the installation and during ongoing operations.

This test covers **Electionware, ExpressVote HW1.0, ExpressVote HW2.1, DS200, ExpressTouch, ExpressVote XL, DS450 and DS850** as well as **Electionware Reporting**.

This suite will be run and is applicable to Configuration A, Configuration B and Configuration C.

- Physical Security Measures.

Physical security testing verifies monitoring and control of the environment of the work place and computing facilities. It also verifies monitor and control access to and from such facilities. For example: doors, locks, cameras, barricades, fencing, cable locks, etc., can be utilized for implementation of physical security. Separating the network and work place into functional areas are also physical controls. Some portions of physical security are functional while other portions are procedural. Functional portions will be tested as appropriate while procedural portions will be verified to be documented as called out by the VVSG.

This test covers **Electionware, ExpressVote HW1.0, ExpressVote HW2.1, DS200, ExpressTouch, ExpressVote XL, DS450 and DS850** as well as **Electionware Reporting**.

This suite will be run and is applicable to Configuration A, Configuration B and Configuration C.

- Telecommunications and Data Transmission

Telecommunications and Data Transmission testing verifies that voting systems which use electrical or optical transmission of data shall ensure the receipt of valid vote records is verified at the receiving station, such that data integrity remains intact. This covers preparation of the system for an election, the execution of an election, and the preservation of the system data and audit trails during and following an election.

This test covers **Electionware, DS450 and DS850** as well as **Electionware Reporting**.

This suite will be run and is applicable to Configuration A, Configuration B and Configuration C.

- **Language** – Testing is conducted to ensure the voting system is capable of presenting the ballot, ballot selections, review screens and instructions in the required languages. The system's ability to handle the prescribed foreign languages that have been declared to be supported, English, Spanish, Chinese, Korean, Japanese, Hindi, Bengali, Vietnamese, Tagalog, Creole, Russian and French will be validated.

This test covers **Electionware, ExpressVote HW1.0, ExpressVote HW2.1, DS200, ExpressTouch, ExpressVote XL, DS450 and DS850** as well as **Electionware Reporting**. Vote counts will be accumulated from **DS450 and DS850, ExpressVote HW2.1, ExpressTouch, ExpressVote XL, and DS200**.

This suite will be run and is applicable to Configuration A, Configuration B and Configuration C.

A second Language test will be run to validate Gujarati and Punjabi for Configuration C.

- **Data Retention/HW Integrity** – Testing integrity requirements ensure the physical stability and function of the vote recording and counting processes, such that the system is not prone to a single point of failure that would prevent voting at a polling place. Testing will also verify prevention of failure of data input or storage, in terms of data retention, as well as confirming that appropriate audit records are maintained without modification. **ES&S** will also provide an attestation that all data is able to be maintained for a minimum of 22 months.

This test covers **Electionware, ExpressVote HW1.0, ExpressVote HW2.1, DS200, ExpressTouch, ExpressVote XL, DS450 and DS850** as well as **Electionware Reporting**. Vote counts will be accumulated from **DS450 and DS850, ExpressVote HW2.1, DS200, ExpressTouch, and ExpressVote XL**.

This suite will be run and is applicable to Configuration A, Configuration B and Configuration C.

- **Accuracy** – Testing the ability of the system to capture, record, store, consolidate and report the specific selections and absence of selections, made by the voter for each ballot position without error. Required accuracy is defined in terms of an error rate that for testing purposes represents the maximum number of errors allowed while processing a specified volume of data.

Accuracy testing is conducted at both the device level and the system level.

Each device is subjected to scrutiny that will verify that the requirements for accuracy are met. Additionally, the system will be reviewed and exercised to validate that the accumulation,

tallying and reporting mechanisms at the system level are able to accurately perform their functions.

The **ExpressVote HW1.0** and **ExpressVote HW2.1** will both be utilized to mark and print vote summary cards, which will then be scanned into an **ExpressVote HW2.1** tabulator, as well as **DS200**, **ExpressVote XL**, **DS450** and **DS850** devices.

There are three potential stages to the accuracy test:

- Go/no go, where after approximately 26,000 ballot positions, if any errors are found the test fails.
- If no errors are found, the test continues to the 1.55 million ballot position mark, where if one error is found the test may progress to approximately the 3.1 million ballot position mark where if no more errors are encountered, the test passes.
- If more than one error is found at the 1.55 million ballot position mark, the test fails.

This test covers **ExpressVote HW1.0**, **ExpressVote HW2.1**, **DS200**, **ExpressTouch**, **ExpressVote XL**, **DS450** and **DS850** as well as **Electionware Reporting**. Vote counts will be accumulated from **DS450** and **DS850**, **ExpressVote HW2.1**, **ExpressTouch**, **ExpressVote XL**, and **DS200**.

This suite will be run and is applicable to Configuration A, Configuration B and Configuration C.

- **Mark Sensitivity** - The purpose of Ballot Mark Sensitivity testing is to determine that the system under test is able to accurately determine when a mark has been made within a ballot marking position. For this test, various marks are made within the ballot marking positions, using EVS supported colors of ink (black), as well as non-supported, in order to determine how the system handles unexpected colors.

Marks include fully filled boxes, left and right oriented slashes, "X" markings, check marks, horizontal single line marks, and circles of various sizes. Marks also include vertical lines within the marking position that fill approximately 10 percent of the designated space. Small dots down to approximately five percent of the ballot marking position are also included.

This test covers **DS200**, **DS450**, **DS850**, as well as the adjudication algorithm within the **Electionware Results** application. Vote counts will be accumulated from **DS450** and **DS850**, and **DS200**.

This suite will be run and is applicable to Configuration A, Configuration B and Configuration C.

- **Volume** – Testing a system's response when subjected to large volumes of data, "more than the expected", as called out in the standards. Volume testing is typically considered a type of non-functional testing. However, as a voting system's primary function is to accumulate, tally, and pass a volume of data (votes) the VSTL approaches volume testing as a functional test. Experience has shown that large amounts of data can slow a system, or even cause failures and loss of data due to architectural limitations. Utilizing the VSTL's experience with voting systems the testing will focus on not only passing large amounts of data but how the system operates and handles the data in key areas of functionality within the voting system.

This test covers **ExpressVote HW1.0, ExpressVote HW2.1, DS200, ExpressTouch, ExpressVote XL, DS450 and DS850** as well as **Electionware Reporting**. Vote counts will be accumulated from **DS450 and DS850, ExpressVote HW2.1, ExpressTouch, ExpressVote XL, and DS200**.

This suite will be run and is applicable to Configuration A, Configuration B and Configuration C.

- **Stress** - Testing a system's "response to transient overload conditions." Experience has shown that when passing a dataset through a system that eclipses the system architectural limitations, failures can occur and result in the loss of critical data. Utilizing the VSTL's experience with voting systems, the testing will focus on the system's ability to operate after the limitations have been exceeded and if failures occur, how the data is maintained or recovered in key areas of functionality within the voting system.

This test covers **ExpressVote HW1.0, ExpressVote HW2.1, DS200, ExpressTouch, ExpressVote XL, DS450 and DS850** as well as **Electionware Reporting**. Vote counts will be accumulated from **DS450 and DS850, ExpressVote HW2.1, ExpressTouch, ExpressVote XL, and DS200**.

This suite will be run and is applicable to Configuration A, Configuration B and Configuration C.

5.6 Standard VSTL Test Methods and Uncertainty of Test Data Measurement

This test campaign utilizes Standard VSTL test methods and election specific type test data only.

5.7 EAC Interpretations

The test engagement described in this Certification Test Plan utilizes only standard VSTL test methods that conform to the EAC Testing and Certification Program Manual and the identified voting system standard. Additional EAC interpretations that affect the test plan and test methodology are as follows:

- EAC Decision on RFI 2007-01
- EAC Decision on RFI 2007-03
- EAC Decision on RFI 2007-04
- EAC Decision on RFI 2007-05
- EAC Decision on RFI 2007-06
- EAC Decision on RFI 2008-01
- EAC Decision on RFI 2008-02
- EAC Decision on RFI 2008-03
- EAC Decision on RFI 2008-04
- EAC Decision on RFI 2008-07
- EAC Decision on RFI 2008-08
- EAC Decision on RFI 2008-09

- EAC Decision on RFI 2008-10
- EAC Decision on RFI 2008-12
- EAC Decision on RFI 2009-02
- EAC Decision on RFI 2009-03
- EAC Decision on RFI 2009-04
- EAC Decision on RFI 2009-05
- EAC Decision on RFI 2009-06
- EAC Decision on RFI 2010-01
- EAC Decision on RFI 2010-02
- EAC Decision on RFI 2010-03
- EAC Decision on RFI 2010-04
- EAC Decision on RFI 2010-06
- EAC Decision on RFI 2010-07
- EAC Decision on RFI 2010-08
- EAC Decision on RFI 2012-01
- EAC Decision on RFI 2012-03
- EAC Decision on RFI 2012-04
- EAC Decision on RFI 2012-05
- EAC Decision on RFI 2012-06
- EAC Decision on RFI 2013-01
- EAC Decision on RFI 2013-02
- EAC Decision on RFI 2013-03
- EAC Decision on RFI 2013-04
- EAC Decision on RFI 2015-05

RFI's not implemented in this test campaign include:

- EAC Decision on RFI 2009-01, VVPAT accessibility
- EAC Decision on RFI 2010-05, modifications of a certified system
- EAC Decision on RFI 2012-02, transmission of official/unofficial results

EAC notices of clarification affecting the certification project are implemented as noted below.

- NOC 2007-005 VSTL responsibilities and Third Party Lab Oversight
- NOC 2008-003 EAC Conformance Testing Requirements
- NOC 2009-001 Test Plan NOC
- NOC 2009-002 Testing Independence
- NOC 2009-004 Test Report
- NOC 2012-02 Clarification of System ID Tool Functionality FINAL 4.19.12
- NOC 2013-01 Discrepancy Listing in Test Report-FINAL-10 17 13
- NOC 2015-01 Test Readiness Review (TRR) applies to both new certs and modifications
- NOC 2016-01 Test Readiness Review
- NOC 2016-02 Trusted Build
- NOC 2016-03 Test Case Upload

EAC notices of clarification, noted below, not affecting the certification project are not implemented:

- NOC 2007-001 Timely Submission of Application for Certification
- NOC 2007-002 VSTL work outside of voting system testing
- NOC 2007-003 State and Federal Testing
- NOC 2007-004 Manufacturing facilities
- NOC 2008-001 Use of Previous Non-core HW Testing
- NOC 2008-002 EAC Mark of Certification
- NOC 2009-003 de minimis change TDP
- NOC 2009-005 Modification Test Plan
- NOC 2011-01 de minimis data change final
- NOC 2012-01 COTS Computer Equivalency for de minimis Change
- NOC 2013-02 Detailed Description of Changes for Modifications
- NOC 2014-01 Technology Testing Agreement

5.8 Security Functions

5.8.1 Security Test

The Security Test Suites are SLI's tests for verifying that a voting system will correspond to requirements in VVSG Volume 1, Section 7. It incorporates systems security provisions, unauthorized access, deletion or modification of data, audit trail data, and modification or elimination of security mechanisms. The vendor documentation will be reviewed to ensure sufficient detail is present to operate the voting system in a secured manner. Where the vendor statements assert the voting system is secured via mechanisms and seals, procedures will test the presence and effectiveness of such controls.

In its security testing SLI identifies the specific threats that are tested for and the associated risk if a flaw or exception is identified in a voting system. SLI maintains a "Known Vulnerabilities Database" that is updated minimally once a year as well as whenever an issue is uncovered. The tests used by SLI are designed to ensure that the voting system meets or exceeds the requirements in the VVSG. Any instance where an anomaly or possible security flaw is identified, the potential risk is reported and evaluated.

Security testing includes testing each individual component of the system and the system as a whole. As such, **Electionware**, **ExpressVote HW1.0**, **ExpressVote HW2.1**, **DS200**, **ExpressTouch**, **ExpressVote XL**, **DS450** and **DS850** as well as **Electionware Reporting** will be subjected to review, as will the system as a whole and its interactions between components.

6 TEST DATA

Test data for the **ES&S EVS 6.0.0.0** voting system is compiled such that all functionality declared will be tested to determine conformance to the standards.

6.1 Data Recording

SLI has evaluated the system functionality, as described by manufacturer technical documentation, as well as requirements as listed in the EAC 2005 VVSG, and made determinations as to expected results of all data inputs into the **ES&S EVS 6.0.0.0** voting system. This includes:

- Election type
- Precincts of all types
- Districts
- Offices
- Contests
- Candidates
- Parties
- Devices used
- Voting variations employed
- Issues/Referendums
- Votes cast for each candidate/issue/referendum
- Vote consolidation data from one device/level to the next

The data is contained in one master data record, including each input and each expected output. This data is incorporated into the appropriate test suite, populating test modules with exact expected data for the function being tested.

Testing information is recorded in the test suites, as well as in test notebooks, which are utilized according to SLI's standard lab procedure *SLP-VC-30 - Test Notebooks*.

6.2 Test Data Criteria

SLI has evaluated the system functionality as described by manufacturer technical documentation, as well as requirements as listed in the EAC 2005 VVSG, and made determinations as to expected output of all data inputs into the **ES&S EVS 6.0.0.0** voting system. A data matrix will be recorded into one master data record that couples data inputs to their expected output, as determined above. The system's execution shall be measured against the expected results.

6.3 Test Data Reduction

SLI processes the test data by manually recording input data into each pertinent module within the Test Suites as well as the exact output that is generated, e.g., the vote counts when the data is consolidated.

7 TEST PROCEDURE AND CONDITIONS

This section describes the test conditions and procedures for execution of test suites. If a particular sequence is mandatory for the execution of suites, a rationale will be given. Additionally, this section is used to describe procedures for setting up equipment that will be utilized in the execution of the test suites.

7.1 Facility Requirements

Testing will be performed on site at SLI in Colorado.

Four secure labs are available with appropriate power supply and space to accommodate the various configurations defined within this Test Plan. Temperature/humidity gauges will be employed in order to determine the appropriate conditions exist during testing.

Unless otherwise specified herein, all remaining tests, including system level functional testing, shall be performed at standard ambient conditions:

- Temperature: 25°C ± 10°C (77°F ± 18°F)
- Relative Humidity: 20 to 90%
- Atmospheric Pressure: Local Site Pressure

All TDP and test documentation is stored on site at SLI's facility in a secure project directory on SLI's secure Voting server.

Environmental hardware testing for hardware components of the **ES&S EVS 6.0.0.0** voting system will be performed at either NVLAP or A2LA accredited testing laboratories or at laboratories audited by SLI to NVLAP Handbook 150-22 requirements.

7.2 Test Setup

Configurations of **ES&S EVS 6.0.0.0** will be deployed that conform to each specific test suite's needs. Some configurations will consist of standalone implementations, while other configurations will utilize networked implementations of various applications, such as **Electionware**, **DS450** and **DS850**. In all instances, **ES&S EVS 6.0.0.0** documentation will be followed in the setup of the configurations.

Successful completion of operational status checks will indicate that the system is ready for test execution.

7.3 Test Sequence

While there is no required sequence for performing voting system certification testing and audits, there are prerequisite tasks for some testing. Any needed prerequisites are contained within the suite for that test.

8 TEST OPERATIONS PROCEDURES

An inventory has been performed to verify the voting equipment received contains hardware and software elements as defined in the TDP prior to commencement of testing.

Throughout the testing effort, test suites and modules will be marked as follows:

- **Accept** – Test is accepted as successful.
- **Reject** – Test is rejected as unsuccessful.
- **NT** – Not Testable is used for test modules that cannot be completed. For example, if failure of one test module precludes attempting subsequent test modules, the latter will be marked as NT.

Test results **Reject** and **NT** will include comments by the VTS explaining the reason for the result.

Issues encountered during review and testing will be documented in the Discrepancy Report as well as reported to the EAC in an authorized manner. Issues that do not conform to the requirements of the VVSG, version 2005 will be marked as **Documentation Discrepancies** or **Functional Discrepancies** (a discrepancy occurs when the software does not meet defined software requirements or specifications). SLI employs a system of checks such that any issue uncovered during testing is first designated as an “anomaly”. The anomaly is then reviewed and the cause is determined as to be either caused by a flaw in the test or in the voting system itself. If the issue is determined to be a flaw in the test, the test will be re-written, re-validated and then formally re-run. If the issue is determined to be a flaw in the voting system, then a discrepancy is opened against the system. While test suites and test modules undergo a validation phase prior to formal execution, last minute code changes can possibly change the behavior from what the test module defines as expected, which if this is the case, the review process employed during the anomaly phase will reveal, thus reducing the chance of a false positive in terms of an unfounded discrepancy being written against the voting system.

Issues that are encountered during testing or documentation review, but are not addressed by the applicable standard will be added to the Discrepancy Report and noted as **Informational**. The vendor has the option whether to address Informational issues.

9 APPROVAL SIGNATURES

SLI:



Traci Mapps
VSTL Director

December 12th, 2017

10 Appendix A – Ancillary Products

Ancillary systems represent products and utilities that are not part of the EAC certified configuration. Ancillary systems include:

- **Ballot Production**
 - Balotar, is a product that allows you to print ad hoc ballots.

- **Ballot Online (intElect) – ExpressPass**
 - Ballot Online is a system that allows a user to access online and make sample ballot selections on any device connected to the Internet. When finished, the output from this system is the ExpressPass – a selection summary with scannable QR code that the user can either print or save in an electronic format on their mobile device.

- **Electronic Pollbook**
 - ExpressPoll electronic pollbook stores registered voter information for precincts, districts, or entire jurisdictions.

- **ExpressLink System**
 - ExpressLink, is a standalone application that interfaces with voter registration (electronic Pollbook) systems and the ExpressVote Activation Card Printer to print the ballot activation code on an ExpressVote activation card. Separately, this application is used to program vote session activator cards for use with ExpressTouch.
 - ExpressVote Activation Card Printer, a thermal, on demand printer used to print the ballot activation code on the ExpressVote activation card.
 - ExpressTouch Smart Card Writer is a device used to program the ballot activation code on the ExpressTouch vote session activator card.

End of Certification Test Plan
